



FAAC para la naturaleza
100% papel reciclado



FAAC ist umweltfreundlich
100% Altpapier



FAAC pour la nature
papier recyclé 100%



FAAC for nature
recycled paper 100%



FAAC per la natura
carta riciclata 100%



940SM-SMD

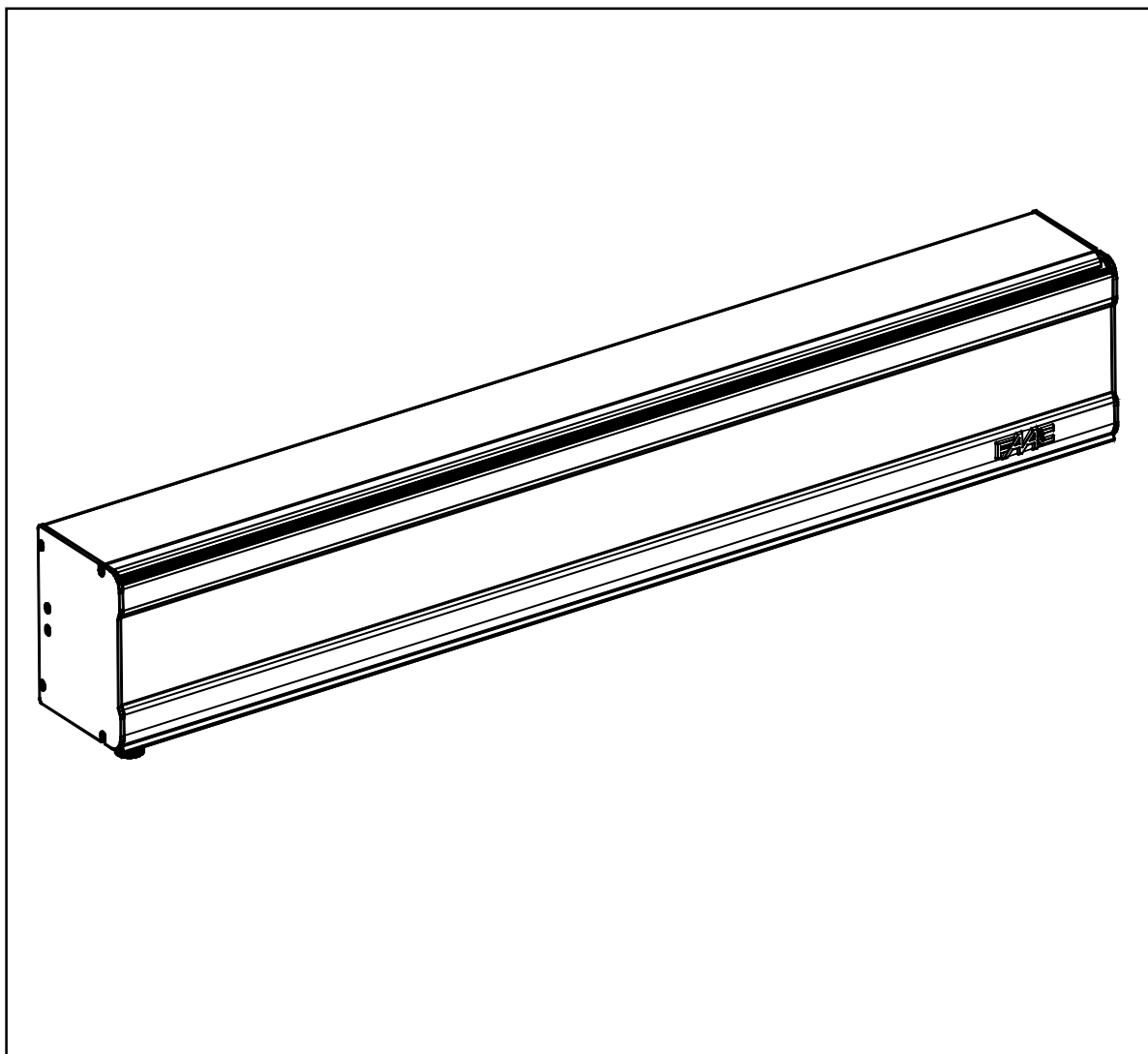

FAAC

CE DECLARATION OF CONFORMITY FOR MACHINES (DIRECTIVE 98/37/EC)

Manufacturer: FAAC S.p.A.

Address: Via Benini, 1 - 40069 Zola Predosa BOLOGNA - ITALY

Declares that: 940 SM - SMD mod. operator

- is built to be integrated into a machine or to be assembled with other machinery to create a machine under the provisions of Directive 98/37/EC;
- conforms to the essential safety requirements of the following EEC directives:

73/23/EEC and subsequent amendment 93/68/EEC.
89/336/EEC and subsequent amendment 92/31/EEC and 93/68/EEC

and also declares that it is prohibited to put into service the machinery until the machine in which it will be integrated or of which it will become a component has been identified and declared as conforming to the conditions of Directive 98/37/EC.

Bologna, 01 January 2003

The Managing Director
A. Bassi



WARNINGS FOR THE INSTALLER GENERAL SAFETY OBLIGATIONS

- 1) **CAUTION! It is important for personal safety to follow all the instructions carefully. Incorrect installation or misuse of the product may cause people serious harm.**
- 2) Read the instructions carefully before starting to install the product.
- 3) Packaging material (plastic, polystyrene, etc.) must not be left within reach of children as it is a potential source of danger.
- 4) Keep the instructions for future reference.
- 5) This product was designed and manufactured strictly for the use indicated in this documentation. Any other not expressly indicated use may damage the product and/or be a source of danger.
- 6) FAAC accepts no responsibility due to improper use of the automated system or use other than that intended.
- 7) Do not install the equipment in an area subject to explosion hazard: inflammable gases or fumes are a serious safety hazard.
- 8) The system must be carried out in compliance with the following Standards: EN 12604, EN 12605, EN 12453, EN 12445. To obtain an adequate level of safety in non EU countries, the above mentioned Standards must be observed in addition to national Standards.
- 9) FAAC will not accept responsibility if the principles of Good Workmanship are disregarded in constructing the closing elements to be motorised, and if any deformation occurs during use of the said elements.
- 10) Before carrying out any work on the system, switch off the power supply.
- 11) The mains power supply of the automated system must be fitted with a all-pole switch with contact opening distance of 3mm or greater. Use of a 6A thermal breaker with all-pole circuit break is recommended.
- 12) Make sure there is a differential switch with 0.03A threshold upstream of the system.
- 13) Check that the earthing system is correctly made and connect the closure metal parts to it.
- 14) The automated system includes an intrinsic anti-crushing device consisting of a torque control which, however, must be installed together with other safety devices.
- 15) The safety devices (EN 12978 Standard) protect any dangerous areas against **Mechanical movement risks**, such as crushing, dragging, and shearing.
- 16) A warning sign adequately fitted on the leaves, in addition to the devices mentioned under point "15", must be used for each system.
- 17) FAAC accepts no responsibility regarding safety and correct operation of the automated system, should components made by manufacturers other than FAAC be used in the system.
- 18) Use only FAAC original spare parts for maintenance.
- 19) Do not make any alterations to the components of the automated system.
- 20) The installer shall supply full information regarding manual operation of the system in case of an emergency.
- 21) Do not allow children or other persons to stand near the product while in operation.
- 22) Keep remote controls or any other pulse generator well away from children, to prevent the automated system from being activated accidentally.
- 23) The user must refrain from attempting to repair or adjust the system personally and should contact qualified personnel only.
- 24) **Anything not expressly provided for in these instructions is not permitted.**

KEY TO PROFILES

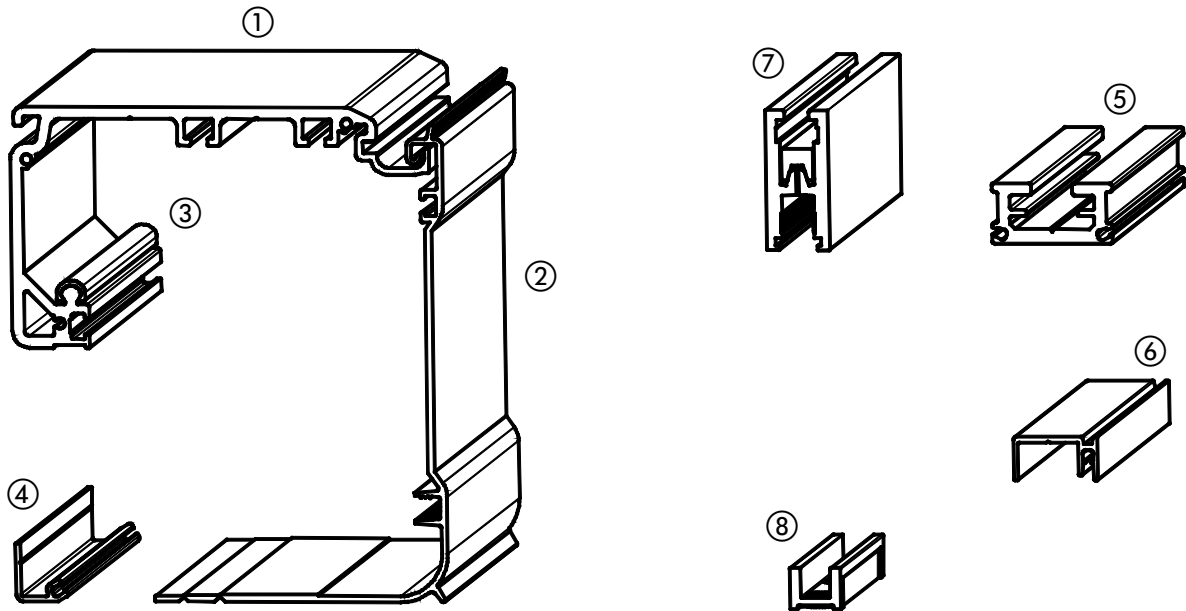

- ① SUPPORT PROFILE
- ② HOUSING PROFILE
- ③ SLIDING PROFILE
- ④ CLOSING PROFILE FOR STANDARD AUTOMATED SYSTEM
- ⑤ LEAF ATTACHMENT PROFILE
- ⑥ LEAF BOTTOM PROFILE
- ⑦ GRIPPER FOR GLASS LEAVES
- ⑧ BOTTOM SLIDING BLOCK FOR GLASS LEAF

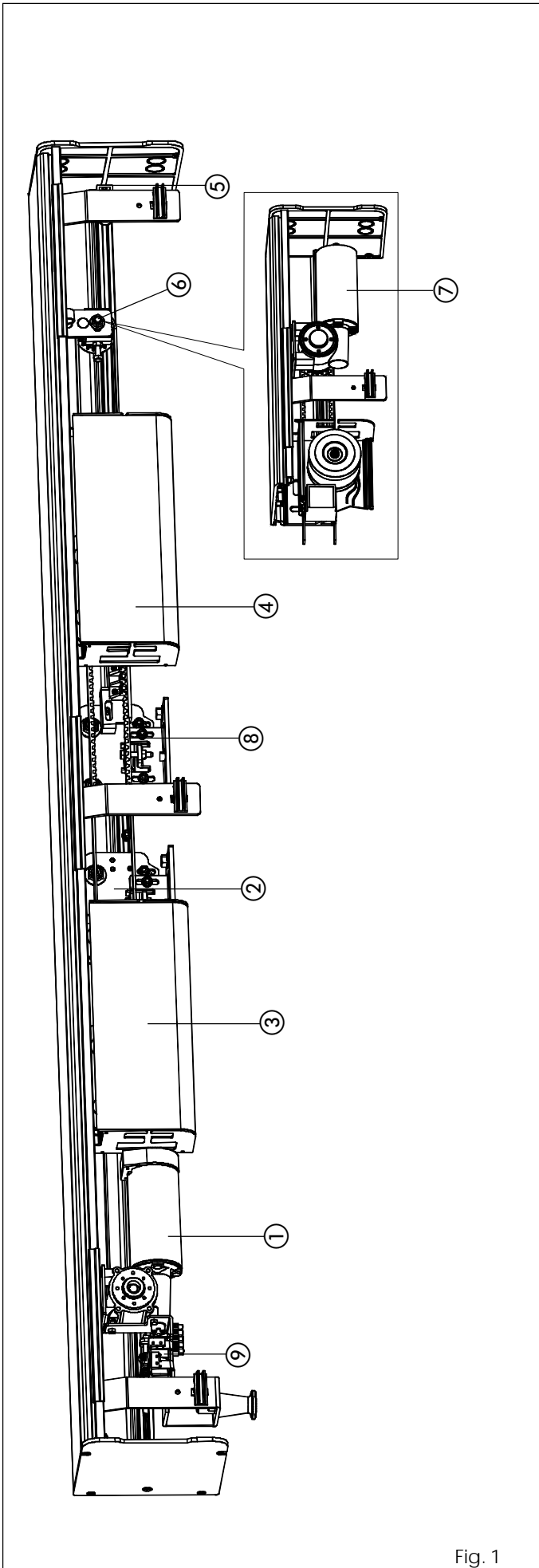
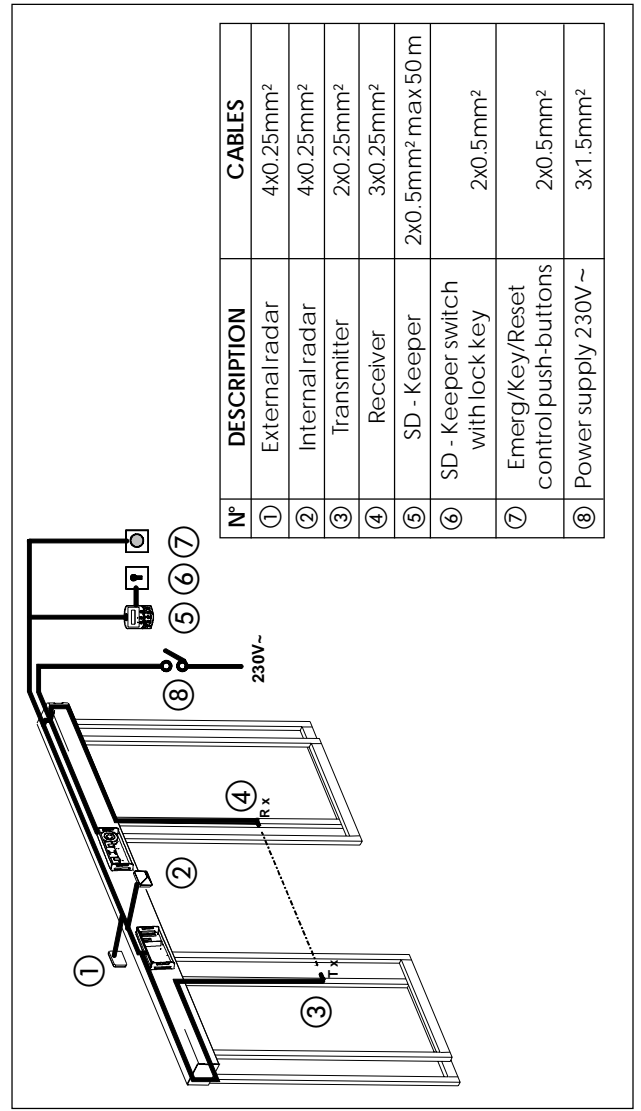

Fig. 1

1. ELECTRICAL EQUIPMENT



N°	DESCRIPTION	CABLES
①	External radar	4x0.25mm ²
②	Internal radar	4x0.25mm ²
③	Transmitter	2x0.25mm ²
④	Receiver	3x0.25mm ²
⑤	SD - Keeper	2x0.5mm ² max 50 m
⑥	SD - Keeper switch with lock key	2x0.5mm ²
⑦	Emerg/Key/Reset control push-buttons	2x0.5mm ²
⑧	Power supply 230V ~	3x1.5mm ²

1. TECHNICAL SPECIFICATIONS

AVAILABLE MODELS	940SM1	940SM2	940SMD1	940SMD2
Head profile	Support	Support	Support	Support
Number of leaves	1	2	1	2
Leaf maximum weight	140	110 + 110	250	180 + 180
Width of free transit space Vp	700÷3000	800÷3000	700÷3000	800÷3000
Max thickness of framed leaf		60 mm		
Max absorbed power	100W			200W
Power supply		115V/ 230V - 50/60Hz		
Protection class		IP 23 (indoor use)		
Anti-crushing activation		on opening /closing		
Operating ambient temperature		-20°C + +55°C		
Use frequency		100%		
Motor power supply		24Vdc		
Head profile length		See figs. 3 to 8		
Opening speed adjustment (load-free)		5 ÷ 70 cm/sec.		10 ÷ 140 cm/sec.
Closing speed adjustment (load-free)		5 ÷ 70 cm/sec.		10 ÷ 140 cm/sec.
Partial opening adjustment		10% ÷ 90%		
Pause time adjustment		0 ÷ 90 sec.		
Night pause time adjustment		0 ÷ 240 sec.		
Failsafe on photocells		can be disabled		

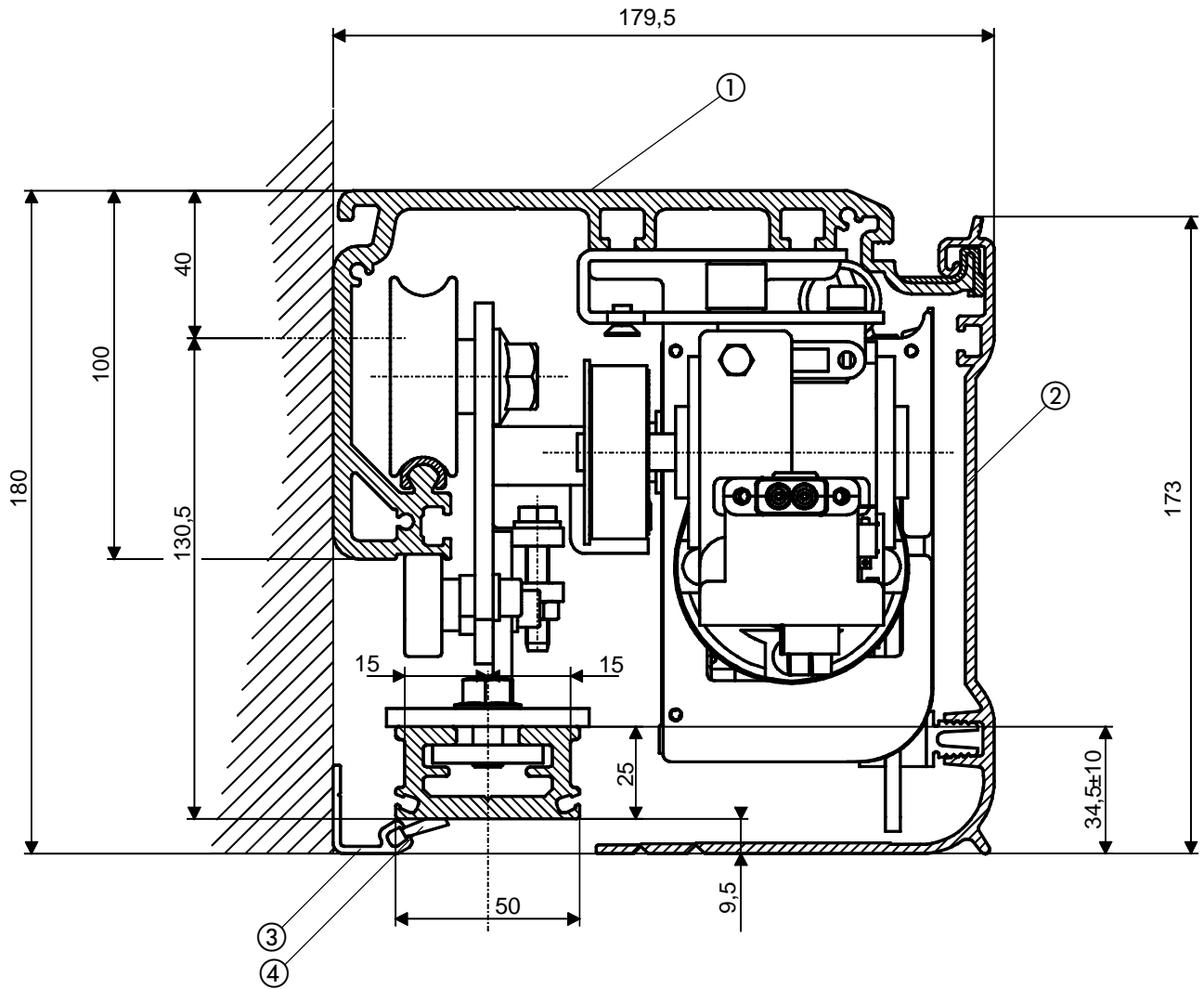

Fig. 2

940SM-SMD SERIES AUTOMATIC DOORS

2. DESCRIPTION AND TECHNICAL SPECIFICATIONS

With the FAAC series 940 SM systems, single- or double-leaf sliding doors can be automatically activated, managed and controlled.

The FAAC series 940 automated systems are supplied fully assembled, wired and tested in the configuration requested by the customer on the order form, or supplied as a kit.

An automation head profile (fig. 1) consists of the following parts:

Profile SM (fig. 2 ref. ①)

This is the support profile which is used when the head profile can be entirely fitted on a bearing structure. The profile's sliding track is coated with a special plastic material which, in addition to protecting the aluminium profile against wear, ensures silent operation with a very low friction coefficient.

Leaf support carriages (fig. 1 ref. ②)

The carriages are provided with two wheels on ball bearings, a counter wheel on the lower part, and a screw system for adjusting leaf height.

Motor unit (fig. 1 ref. ①)

The DC motor is supplied with an encoder and a leaf locking system (accessory).

Control unit (fig. 1 ref. ③)

When the microprocessor control unit is powered up, it executes an initialisation process of the door's functional parameters.

Transformer (fig. 1 ref. ④)

Opening mechanical stop (fig. 1 ref. ⑤)

Transmission pulley unit (fig. 1 ref. ⑥)

Second motor (fig. 1 ref. ⑦)

Drive chain (fig. 1 ref. ⑧)

3. ACCESSORIES

FAAC has three groups of articles complementing the installation of the automatic door.

3.1 Supplied accessories for the head profile

These are the articles which, following a request on the order form, are assembled on the head profile directly by FAAC. These accessories, which can be, if necessary, installed later on, are as follows:

Front housing (fig. 2 ref. ②)

The front housing is available in natural or anodised aluminium. The side panels fully enclose the system.

Motor lock unit

The motor lock unit guarantees mechanical locking of the door in any position. A single type of motor lock is used for either single- or double-leaf applications.

The motor lock is supplied with an internal release device (fig. 1 ref. ⑨) enabling emergency opening if necessary; it is also designed for installation of the external release (paragraph 3.2 key push-buttons T21EF and T21IF). The motor lock unit acts directly on the motor by locking it mechanically.

Motor lock control

This controls if the motor lock operating efficiently and checks if the door has actually closed. If necessary, the system is designed for remote activation of an indicator-light or buzzer.

Emergency batteries (fig. 1 ref. ④)

In the event of a mains power cut, on-battery operation provides a range of 30 minutes at 100% use frequency. The battery charge status test is automatic and indicated by a LED.

The charge control board is designed for remote activation of a 'battery operating' signal.

3.2 Supplementary accessories

These are the peripheral accessories for completing the automated system.

-Miniswitch photocells

-T20E : outdoor key-operated selector switch

-T20I : flush-fitting key-operated selector switch

-T21EF : Outdoor key-operated selector switch designed for motor release

-T21IF : Flush-fitting key-operated selector switch designed for motor release

-Detection sensors.

-SD Keeper

3.3 Door frame accessories

To facilitate adapting the door frame profile to the carriages and to enable correct finishing of the installation, FAAC offers the following series of articles:

Closing profile (fig. 2 ref. ③)

Available in natural and anodised aluminium versions, the profile is used for closing the space between the mobile leaf and the wall on which the head profile is secured.

Brush for closing profiles (fig. 2 ref. ④)

Prevents dust reaching inside the head profile.

Pair of sliding blocks (fig. 13 ref. 2)

Supplied as a pair, they can be secured to the wall (or on the stationary leaf) or directly on the floor.

Bottom track profile (fig. 13 ref. ①)

Allows the bottom leaf profile to adapt to the sliding block mentioned above.

Brush for bottom track profile (fig. 13 ref. ③)

This completes the on-ground track system.

Leaf attachment profile (fig. 16 ref. ③)

Allows the top leaf profile to adapt to the carriage attachments.

Pair of bottom sliding blocks for glass leaf

They enable the glass leaves to slide.

4. HEAD PROFILE CONFIGURATION

To correctly position the head profile parts, refer to the dimensions in figures 3, 4 and 5 for model SM and figures 6, 7 and 8 for twin-motor model (SDM).

940 SM Right opening

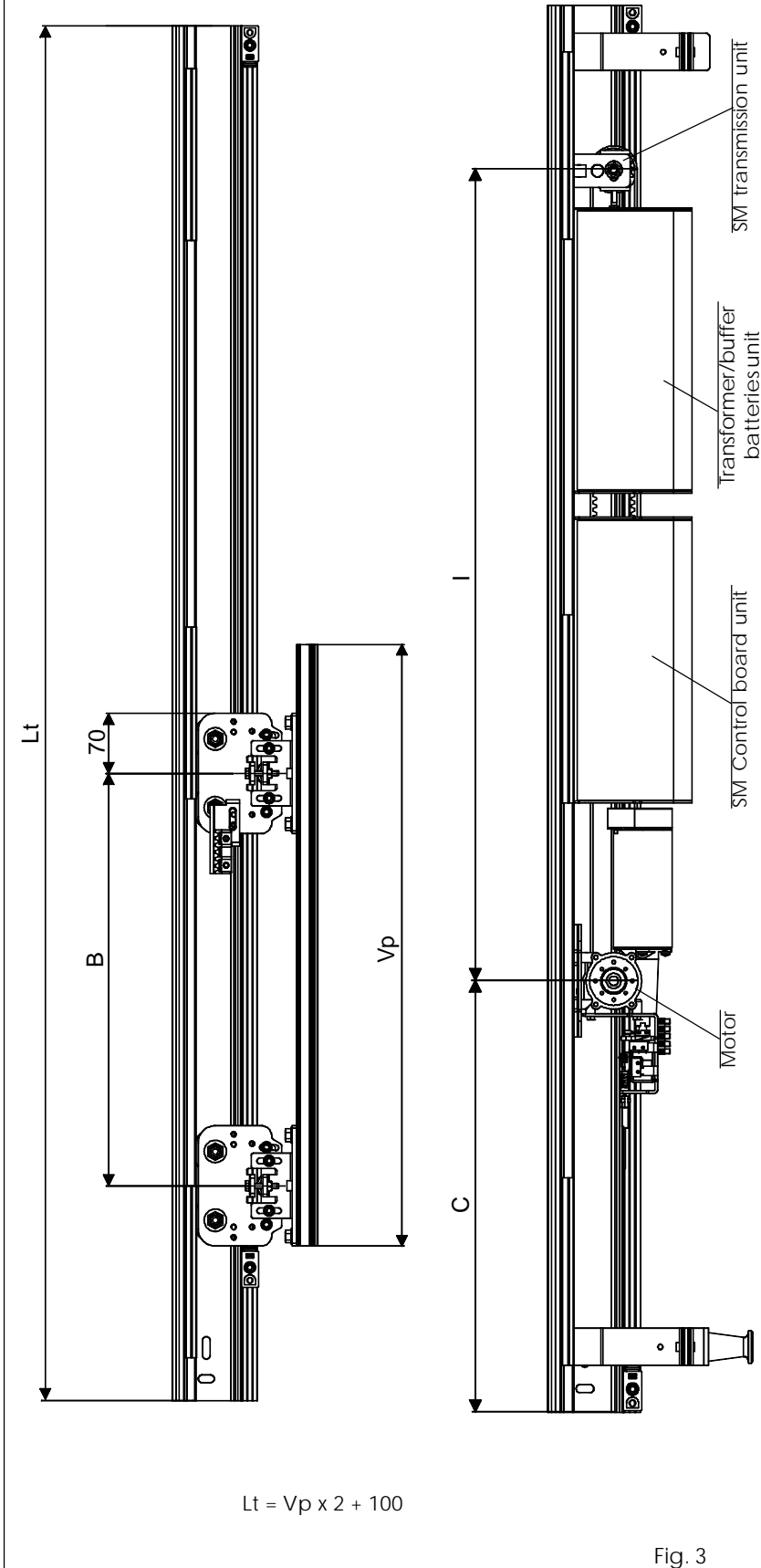

Vp	Lt	B	C	D	I
700	1500	490	335	1870	865
800	1700	590	535	2070	965
900	1900	690	635	2270	1065
1000	2100	790	735	2470	1165
1100	2300	890	835	2670	1265
1200	2500	990	935	2870	1365
1300	2700	1090	1035	3070	1465
1400	2900	1190	1135	3270	1565
1500	3100	1290	1235	3470	1665
1600	3300	1390	1335	3670	1765
1700	3500	1490	1435	3870	1865
1800	3700	1590	1535	4070	1965
1900	3900	1690	1635	4270	2065
2000	4100	1790	1735	4470	2165
2100	4300	1890	1835	4670	2265
2200	4500	1990	1935	4870	2365
2300	4700	2090	2035	5070	2465
2400	4900	2190	2135	5270	2565
2500	5100	2290	2235	5470	2665
2600	5300	2390	2335	5670	2765
2700	5500	2490	2435	5870	2865
2800	5700	2590	2535	6070	2965
2900	5900	2690	2635	6270	3065
3000	6100	2790	2735	6470	3165

Vp = Free transit space
 Lt = Head profile length
 B = Securing distance of carriages on sliding leaf
 C = Motor positioning dimension
 D = Length of transmission belt
 I = Motor/transmission unit distance

Fig. 3

940 SM Left opening

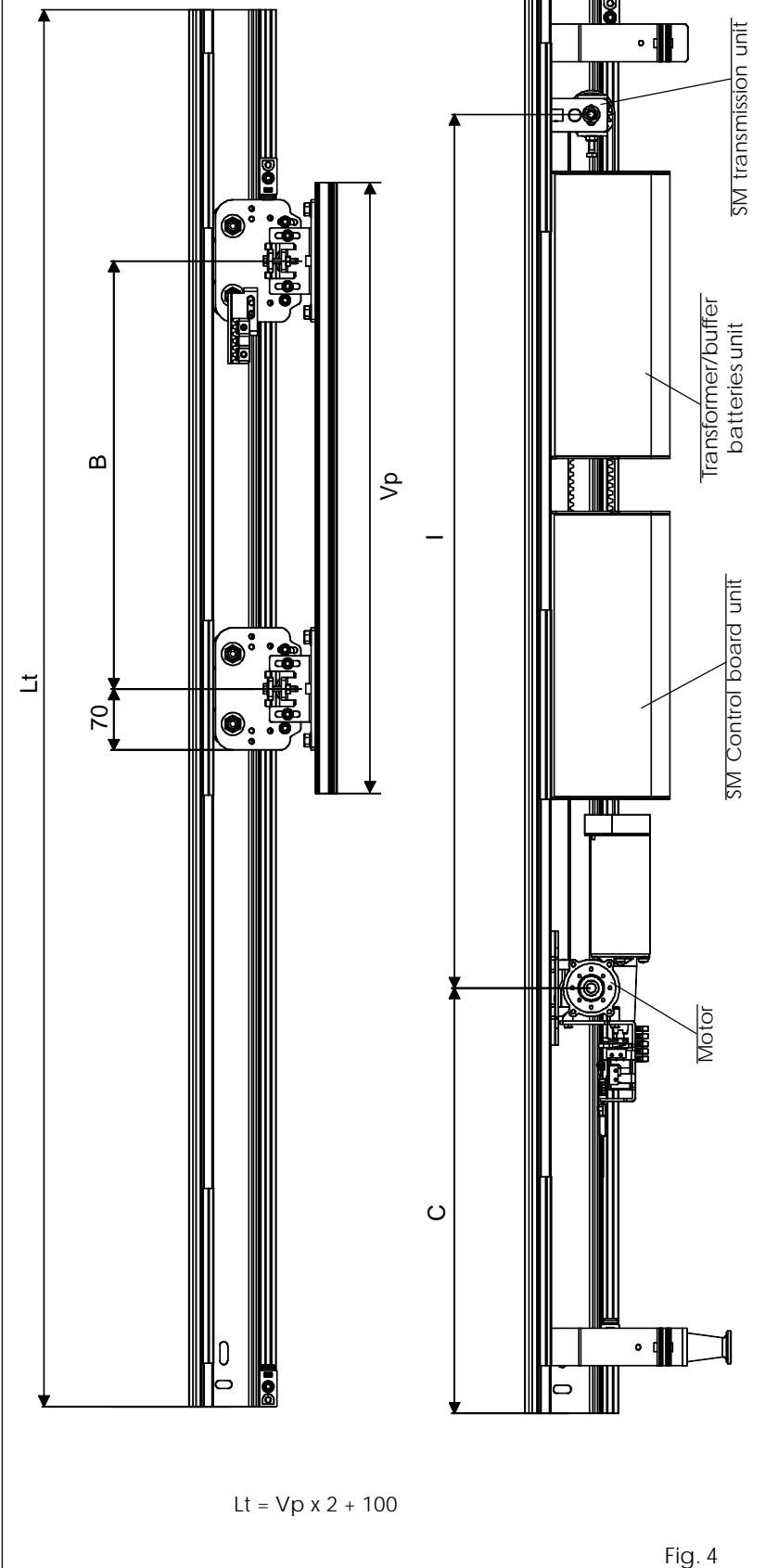
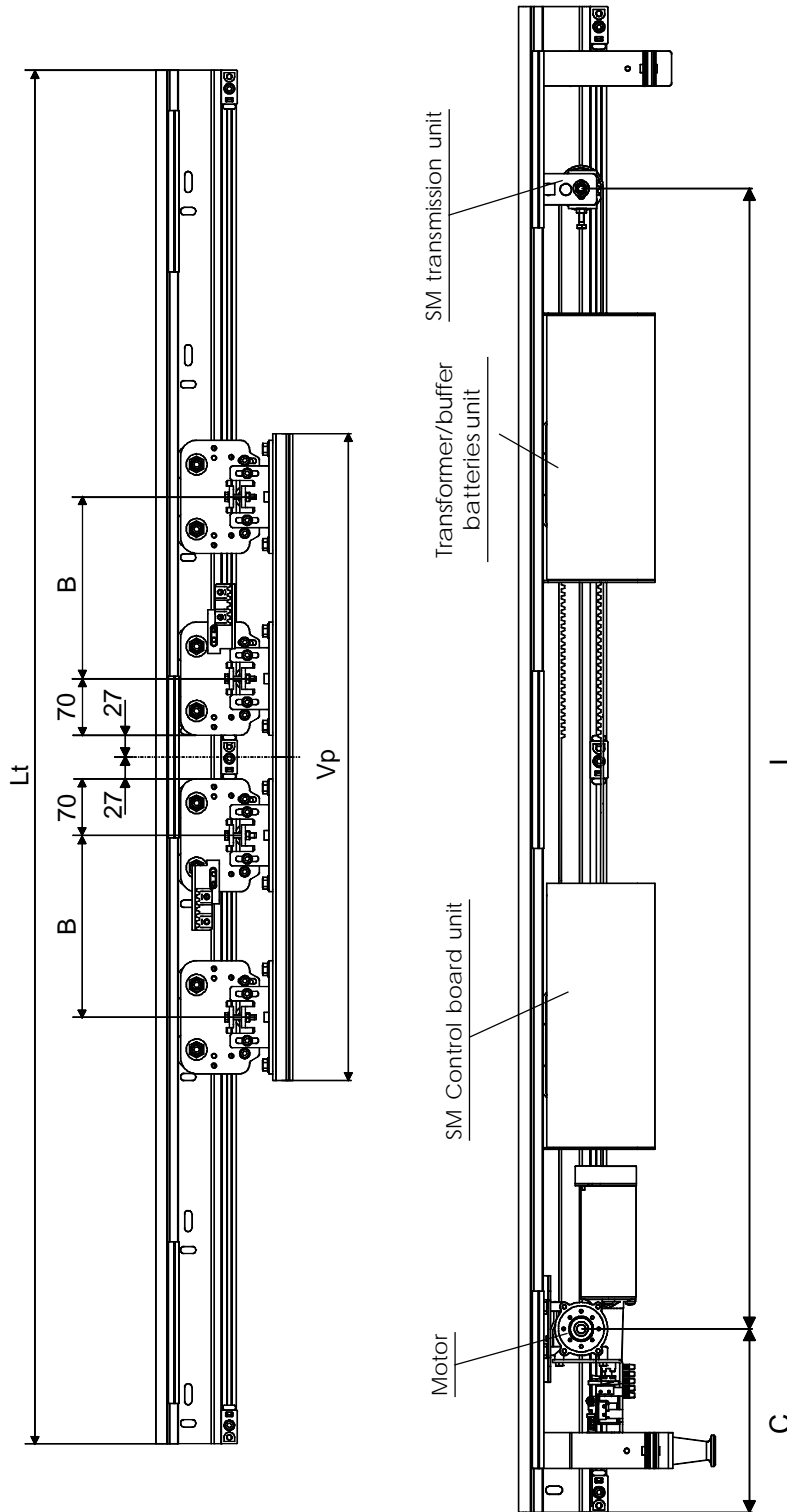

Fig. 4

Vp	Lt	B	C	D	I
700	1500	510	450	1990	925
800	1700	590	585	2070	965
900	1900	690	685	2270	1065
1000	2100	790	785	2470	1165
1100	2300	890	885	2670	1265
1200	2500	990	985	2870	1365
1300	2700	1090	1085	3070	1465
1400	2900	1190	1185	3270	1565
1500	3100	1290	1285	3470	1665
1600	3300	1390	1385	3670	1765
1700	3500	1490	1485	3870	1865
1800	3700	1590	1585	4070	1965
1900	3900	1690	1685	4270	2065
2000	4100	1790	1785	4470	2165
2100	4300	1890	1885	4670	2265
2200	4500	1990	1985	4870	2365
2300	4700	2090	2085	5070	2465
2400	4900	2190	2185	5270	2565
2500	5100	2290	2285	5470	2665
2600	5300	2390	2385	5670	2765
2700	5500	2490	2485	5870	2865
2800	5700	2590	2585	6070	2965
2900	5900	2690	2685	6270	3065
3000	6100	2790	2785	6470	3165

Vp = Free transit space
 Lt = Head profile length
 B = Securing distance of carriages on sliding leaf
 C = Motor positioning dimension
 D = Length of transmission belt
 I = Motor/transmission unit distance

940 SM Double-leaf



$Lt = Vp \times 2 + 100$

Fig. 5

Vp	Lt	B	C	D	I
800	1700	225	205	2710	1285
900	1900	275	257,5	2910	1385
1000	2100	325	307,5	3110	1485
1100	2300	375	357,5	3310	1585
1200	2500	425	407,5	3510	1685
1300	2700	475	457,5	3710	1785
1400	2900	525	507,5	3910	1885
1500	3100	575	557,5	4110	1985
1600	3300	625	607,5	4310	2085
1700	3500	675	657,5	4510	2185
1800	3700	725	707,5	4710	2285
1900	3900	775	757,5	4910	2385
2000	4100	825	807,5	5110	2485
2100	4300	875	857,5	5310	2585
2200	4500	925	907,5	5510	2685
2300	4700	975	957,5	5710	2785
2400	4900	1025	1007,5	5910	2885
2500	5100	1075	1057,5	6110	2985
2600	5300	1125	1107,5	6310	3085
2700	5500	1175	1157,5	6510	3185
2800	5700	1225	1207,5	6710	3285
2900	5900	1275	1257,5	6910	3385
3000	6100	1325	1307,5	7110	3485

- Vp = Free transit space
- Lt = Head profile length
- B = Securing distance of carriages on sliding leaf
- C = Motor positioning dimension
- D = Length of transmission belt
- I = Motor/transmission unit distance

940 SMD Right opening

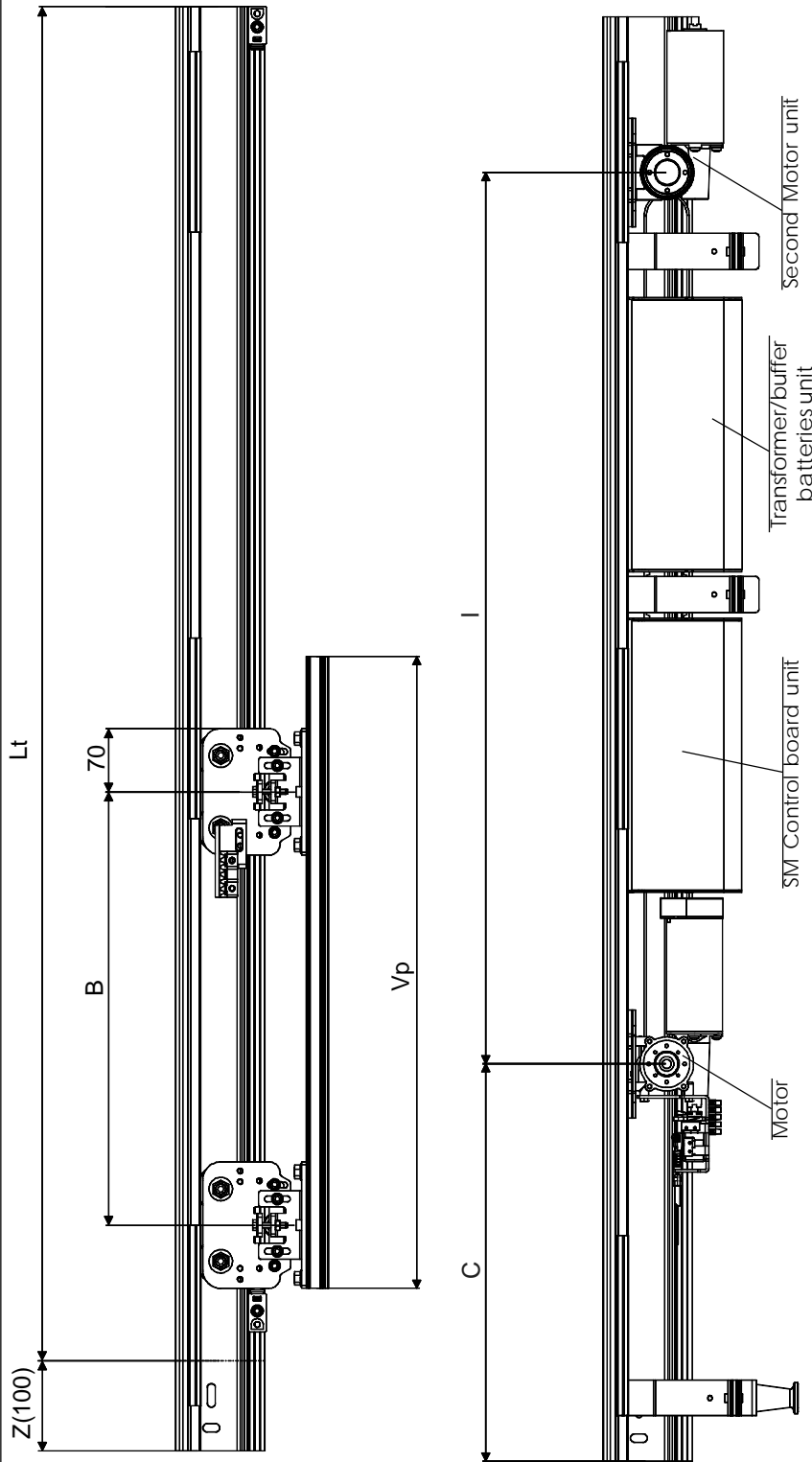

If $700 \leq Vp \leq 1100$ then
 $Lt = Vp \times 2 + 200$

If $Vp > 1100$ then
 $Lt = Vp \times 2 + 100$

Fig. 6

Vp	Lt	B	C	D	I
700	1600	490	420	2040	950
800	1800	590	435	2240	1050
900	2000	690	535	2440	1150
1000	2200	790	635	2640	1250
1100	2400	890	735	2840	1350
1200	2500	990	835	2870	1365
1300	2700	1090	935	3070	1465
1400	2900	1190	1035	3270	1565
1500	3100	1290	1135	3470	1665
1600	3300	1390	1235	3670	1765
1700	3500	1490	1335	3870	1865
1800	3700	1590	1435	4070	1965
1900	3900	1690	1535	4270	2065
2000	4100	1790	1635	4470	2165
2100	4300	1890	1735	4670	2265
2200	4500	1990	1835	4870	2365
2300	4700	2090	1935	5070	2465
2400	4900	2190	2035	5270	2565
2500	5100	2290	2135	5470	2665
2600	5300	2390	2235	5670	2765
2700	5500	2490	2335	5870	2865
2800	5700	2590	2435	6070	2965
2900	5900	2690	2535	6270	3065
3000	6100	2790	2635	6470	3165

Vp = Free transit space
 Lt = Head profile length
 B = Securing distance of carriages on sliding leaf
 C = Motor positioning dimension
 D = Length of transmission belt
 I = Motor/second motor distance

940 SMD Left opening

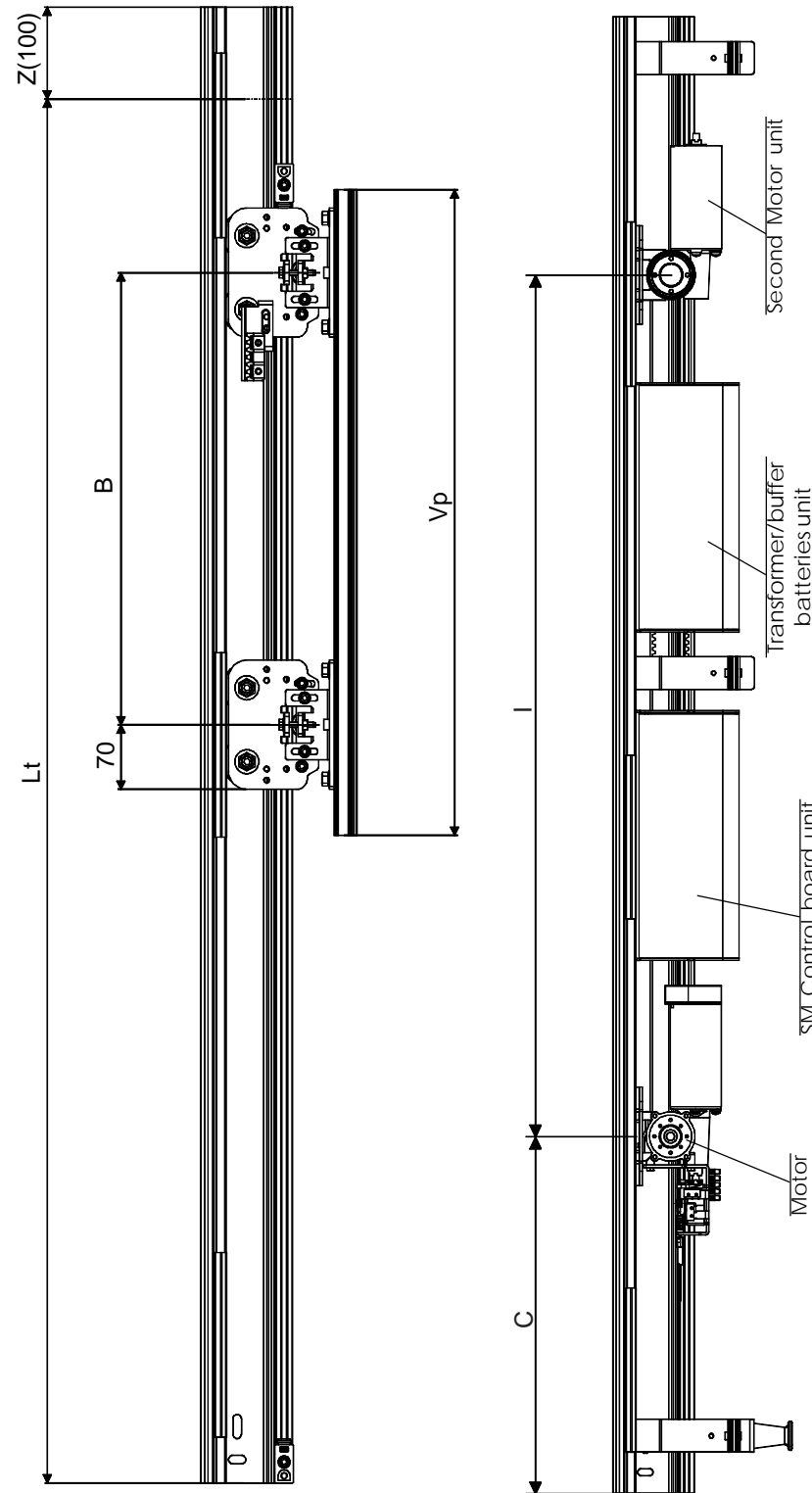

If $700 \leq Vp \leq 1100$ then
 $Lt = Vp \times 2 + 200$

If $Vp > 1100$ then
 $Lt = Vp \times 2 + 100$

Vp	Lt	B	C	D	I
700	1600	480	440	2100	980
800	1800	590	485	2300	1080
900	2000	690	585	2500	1180
1000	2200	790	685	2700	1280
1100	2400	890	785	2900	1380
1200	2500	990	885	2870	1365
1300	2700	1090	985	3070	1465
1400	2900	1190	1085	3270	1565
1500	3100	1290	1185	3470	1665
1600	3300	1390	1285	3670	1765
1700	3500	1490	1385	3870	1865
1800	3700	1590	1485	4070	1965
1900	3900	1690	1585	4270	2065
2000	4100	1790	1685	4470	2165
2100	4300	1890	1785	4670	2265
2200	4500	1990	1885	4870	2365
2300	4700	2090	1985	5070	2465
2400	4900	2190	2085	5270	2565
2500	5100	2290	2185	5470	2665
2600	5300	2390	2285	5670	2765
2700	5500	2490	2385	5870	2865
2800	5700	2590	2485	6070	2965
2900	5900	2690	2585	6270	3065
3000	6100	2790	2685	6470	3165

Vp = Free transit space
 Lt = Head profile length
 B = Securing distance of carriages on sliding leaf
 C = Motor positioning dimension
 D = Length of transmission belt
 I = Motor/second motor distance

Fig. 7

940 SMD Double-leaf

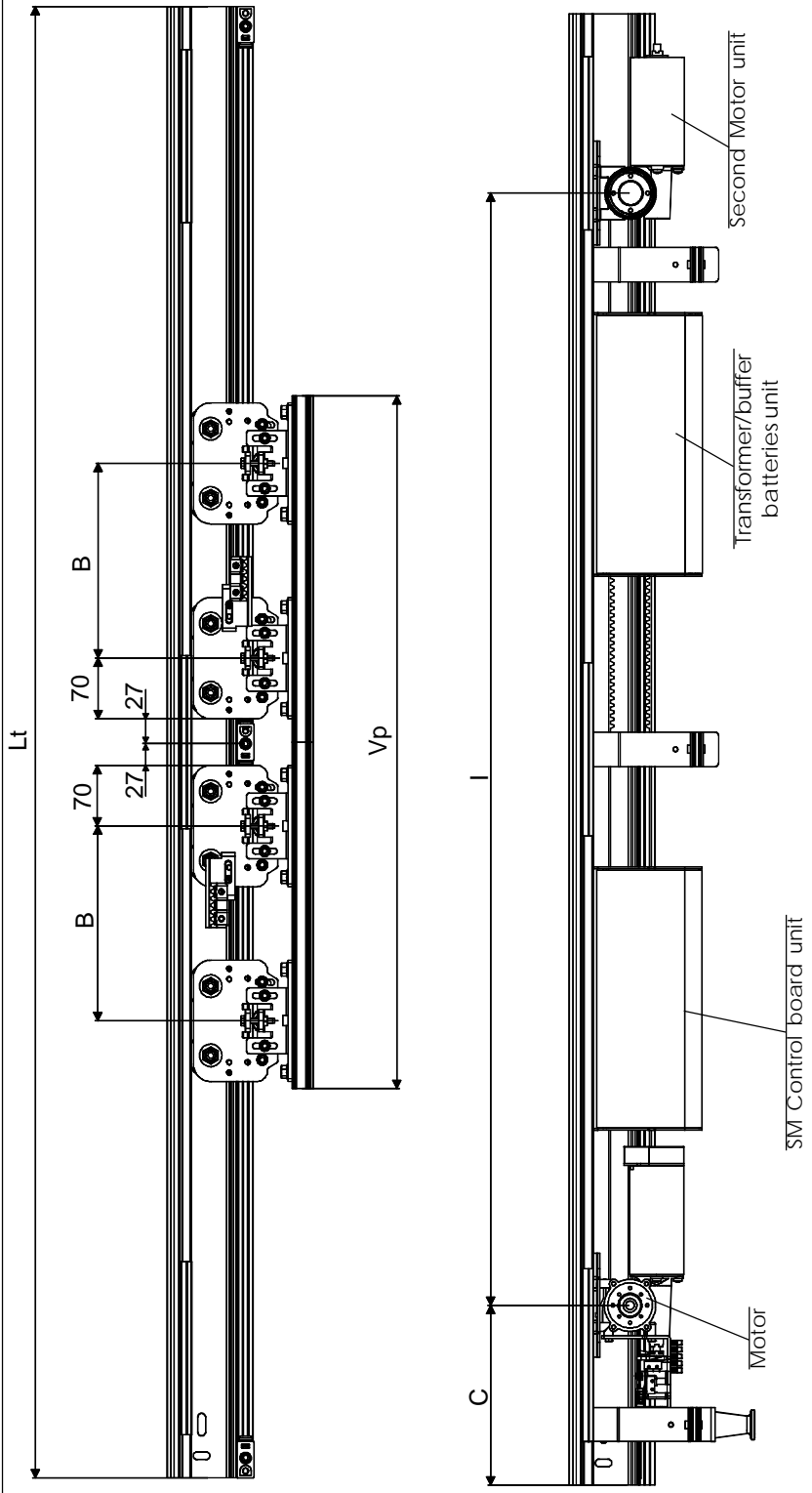

$L_t = V_p \times 2 + 100$

Vp	Lt	B	C	D	I
800	1700	225	205	2710	1285
900	1900	275	257,5	2910	1385
1000	2100	325	307,5	3110	1485
1100	2300	375	357,5	3310	1585
1200	2500	425	407,5	3510	1685
1300	2700	475	457,5	3710	1785
1400	2900	525	507,5	3910	1885
1500	3100	575	557,5	4110	1985
1600	3300	625	607,5	4310	2085
1700	3500	675	657,5	4510	2185
1800	3700	725	707,5	4710	2285
1900	3900	775	757,5	4910	2385
2000	4100	825	807,5	5110	2485
2100	4300	875	857,5	5310	2585
2200	4500	925	907,5	5510	2685
2300	4700	975	957,5	5710	2785
2400	4900	1025	1007,5	5910	2885
2500	5100	1075	1057,5	6110	2985
2600	5300	1125	1107,5	6310	3085
2700	5500	1175	1157,5	6510	3185
2800	5700	1225	1207,5	6710	3285
2900	5900	1275	1257,5	6910	3385
3000	6100	1325	1307,5	7110	3485

Vp = Free transit space
 Lt = Head profile length
 B = Securing distance of carriages on sliding leaf
 C = Motor positioning dimension
 D = Length of transmission belt
 I = Motor/second motor distance

Fig. 8

5. INSTALLATION

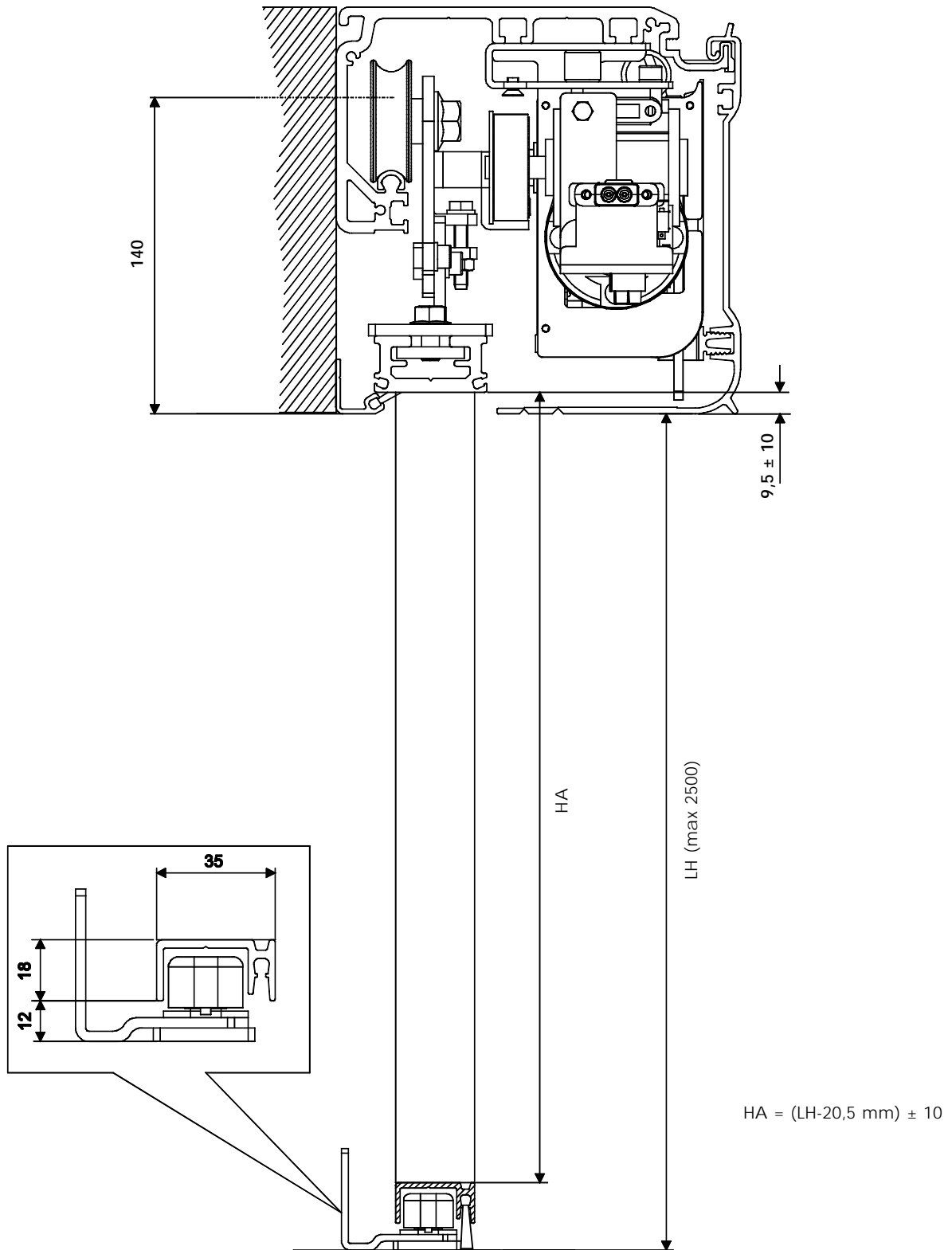

Fig. 9

6. SECURING THE HEAD PROFILE

The support profile is used when the head profile can be fully fixed to a metal or masonry bearing structure not showing significant deformations.

Support profile - securing it to the wall

- Establish the exact location of the head profile considering the overall dimensions of fig. 2. The head profile must be secured parallel to the floor.
 - To begin with, fit the head profile on a vertical slot at one end and on a horizontal slot at the other end (using M8 screws and appropriate expansion plugs), and level parallel to the floor.
- Secure at the centre, firmly lifting the head profile to align the three securing points. Carry out the remaining securing operations, alternating vertical and horizontal slots (fig. 10).

ATTENTION: insert the brush (accessory fig. 11 ref. ①) in the closing profile before installing.

6.1 Installation of side panels

- Fit the side panels as shown in figures 12.
- The side panels are engraved so that they can adapt to head profiles with or without a free-standing profile.

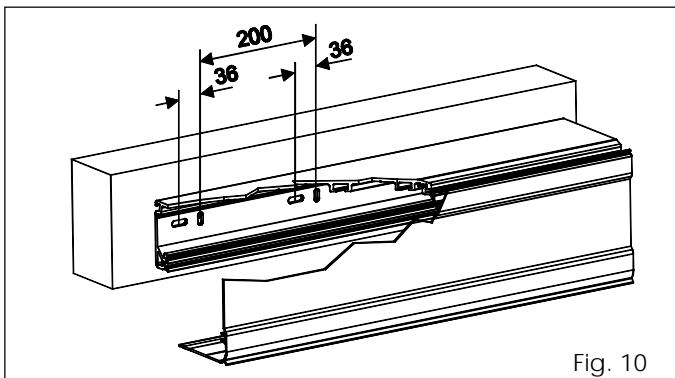

Fig. 10

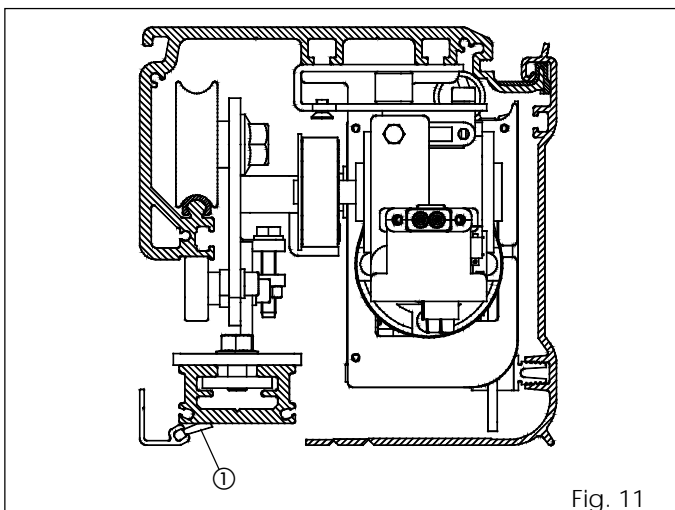

Fig. 11

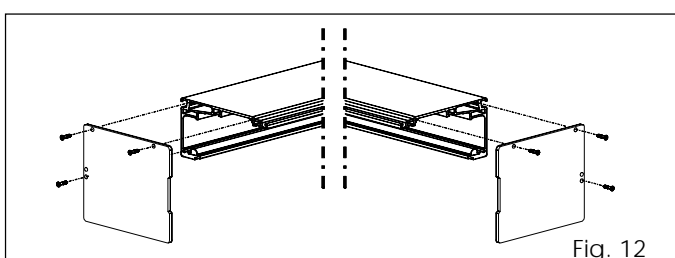

Fig. 12

7. INSTALLATION OF BOTTOM SLIDING BLOCKS

The bottom sliding blocks are designed for securing to the wall (or stationary leaf) or to the floor.

Securing on the wall (or on stationary leaf):

- Assemble the sliding blocks, considering in mind the dimensions in figs. 13 and 15.
- Secure the sliding blocks as shown in fig. 14. ref. ①.

Securing on the floor

- Secure the sliding block directly to the floor, as shown in fig. 14. ref. ②, using adequate expansion plugs and screws.

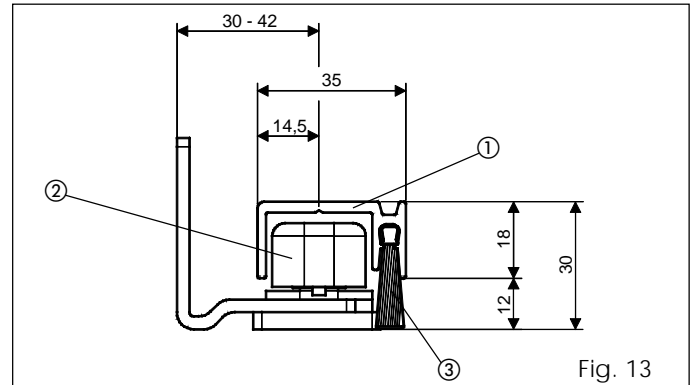

Fig. 13

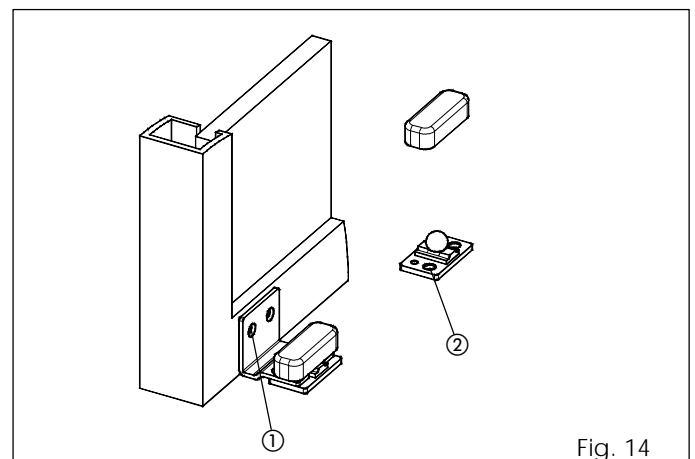

Fig. 14

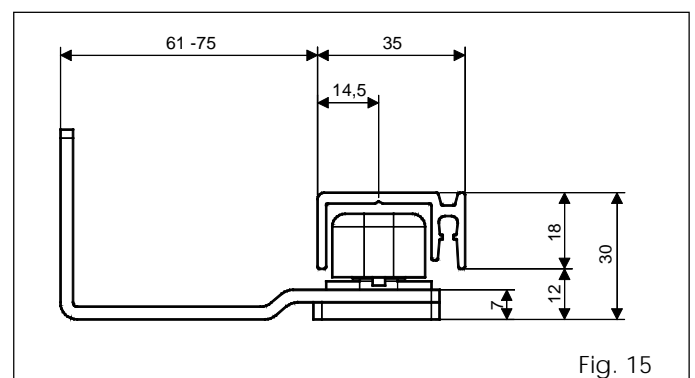

Fig. 15

8. INSTALLATION OF THE LEAVES

- Fit the leaf attachment profile (accessory fig. 16 ref. ③) on the top of the leaf, using adequate screws.
- Secure the leaf on the relevant carriages, using the supplied plates (fig. 16 ref. ①) and screws (fig. 16 ref. ②).
- Position the carriages of the automated system as shown in figures from 3 to 8.
- Tighten the screws of the carriages.

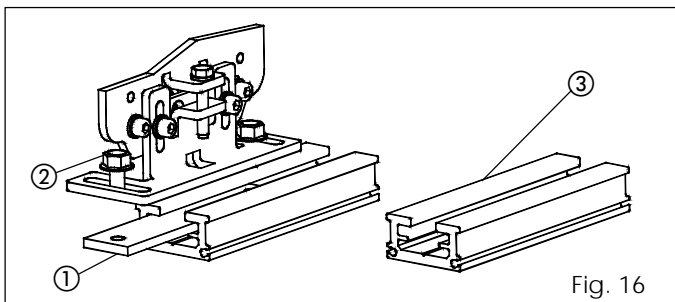

Fig. 16

8.1 Leaf adjustment

The carriages enable height adjustment of the leaves.

Adjustment procedure:

- Slightly loosen the two hexagon head screws in fig. 17 ref. ①.
- Turn the screw (fig. 17 ref. ②) clockwise to raise the leaves or anti-clockwise to lower them.
- Re-tighten the screws.

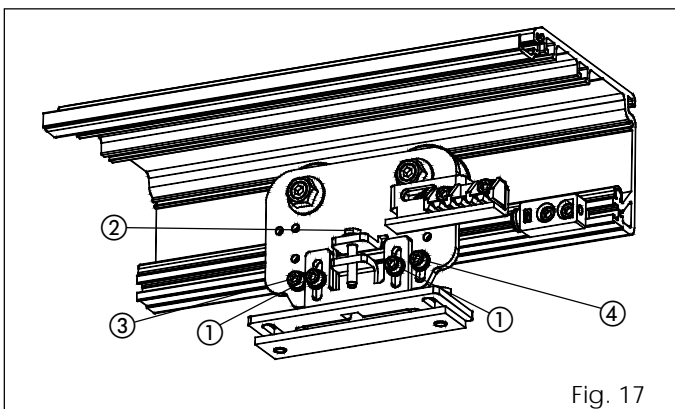

Fig. 17

8.2 Adjustment of the counter roller

The carriages are supplied with a counter wheel. Adjustment procedure below:

- Loosen the two hexagon head screws (fig. 17 ref ③ and ④).
- Slide the screw fig. 17 ref. ④ inside the slot, so that, while the carriage is moving, the counter wheel slides on the profile without jamming.

Check if the wheel can be locked without stopping the carriage.

9. ADJUSTMENT OF THE TRAVEL STOP LIMITS

Adjustment of the opening mechanical stops

The 940 SM series doors are supplied with the opening mechanical stops mounted on the sliding profile.

Make sure that, when the leaves are being opened, the sliding carriages simultaneously reach the opening travel limit mechanical stops.

If adjustments are necessary, proceed as follows:

- Take the leave into opening position.
- Loosen the two hexagon head screws as shown in figures 18 and 19 ref. ①.
- Take the mechanical stop toward the carriage until the two parts come into contact.
- Tighten the two hexagon head screws.

Adjustment of the closing mechanical stop.

The 940 SM series doors are supplied with the carriages reaching their travel stop limit on the closing edge (fig. 20). If the door centre has to be adjusted, proceed as follows:

- Loosen the fixing screws (fig. 20 ref. ①) of the carriage in question. Take the carriage toward the limit stop until the two parts are in contact.
- Tighten the carriage's fixing screws.

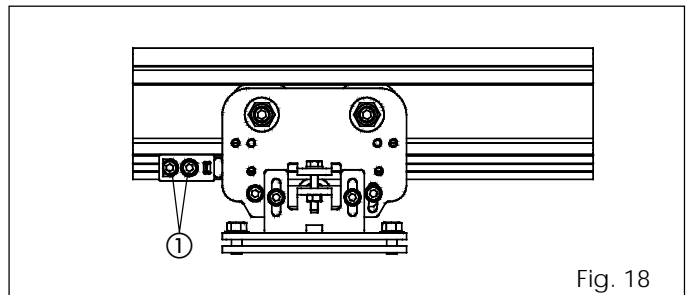

Fig. 18

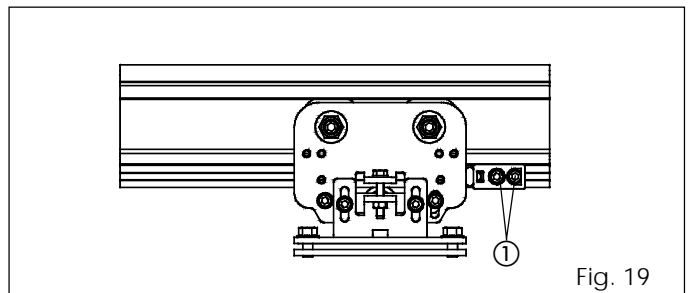

Fig. 19

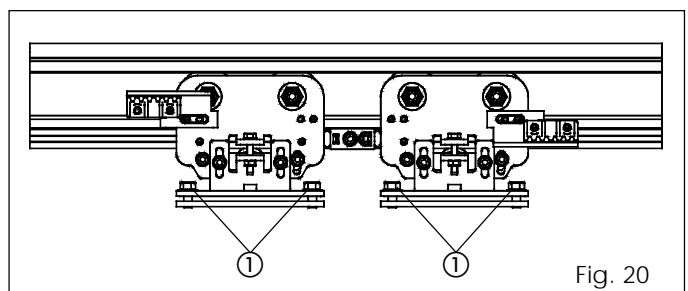

Fig. 20

10. BELT ADJUSTMENT

Check if the belt is too slack or taut.

Belt tension adjustment procedure:

- Loosen the nut (fig. 21 ref. ①).
- Screw the bolt of fig. 21 ref. ② to exert tension on the belt or unscrew it to slacken the belt.
- When you have adjusted tension, tighten the nut (fig. 21 ref. ①).

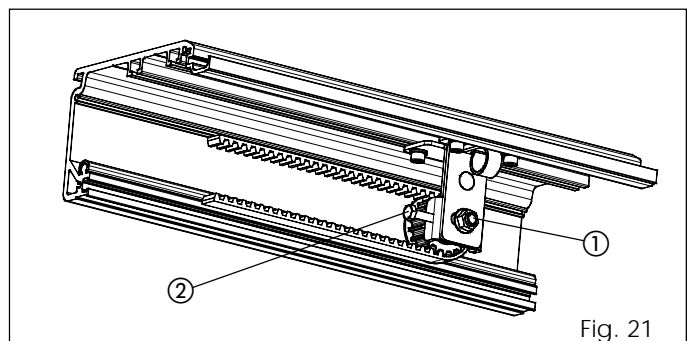

Fig. 21

To adjust belt tension for twin-motor doors, proceed as follows:

- Slightly loosen the four fixing screws (fig. 22 ref. ①) of the second motor.
- Push the motor unit outwards using a hammer as shown in fig. 22.
- When you have adjusted tension, tighten the four screws.

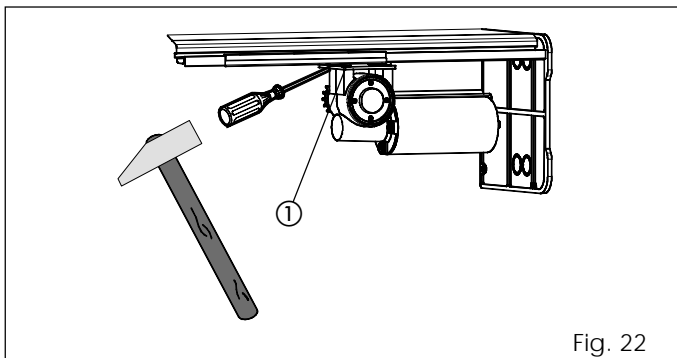

Fig. 22

11. INSTALLATION OF HOUSING FIXING BRACKETS

- Fit a housing fixing bracket at the end of the head profile, opposite the motor unit, using the supplied screws and plates (fig.23).
 - Fit the second housing fixing bracket slightly off-centre of the head profile, to enable you to make the door-centre adjustments.
 - Secure the bracket supporting the internal release knob to the other end of the head profile (on the motor unit side), as shown in fig. 24.
- The support bracket of the internal release knob must always be installed, even if the motor lock is not used.

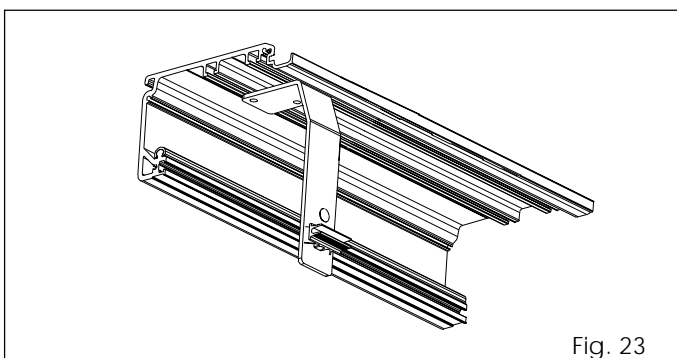

Fig. 23

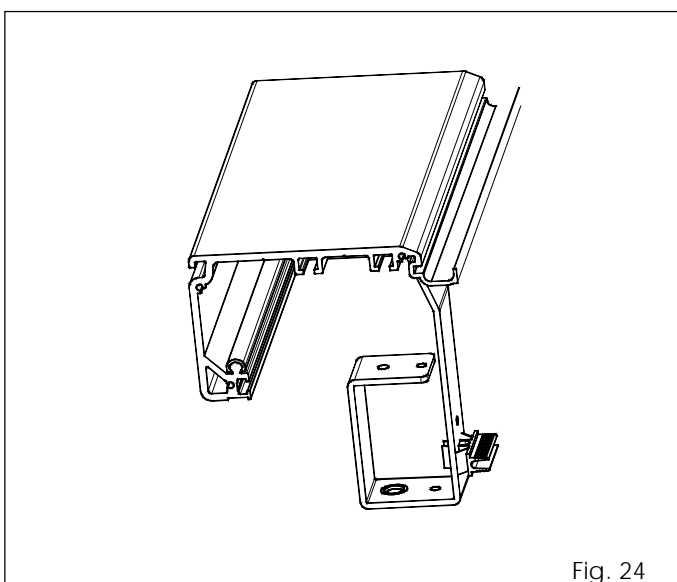

Fig. 24

12. MOTOR LOCK

The motor lock is a device guaranteeing the leaves are locked when closed. Installation procedure:

- Secure the motor lock with the two supplied bolts as shown in fig. 25 ref. ①.
- Manually push the lever (fig. 26 ref. ①) toward the motor shaft, checking for correct meshing as per fig. 26 ref. A.
- Move the lever (fig. 26 ref. ①) vertically and check if there is play between the motor-shaft and motor-lock coupling.

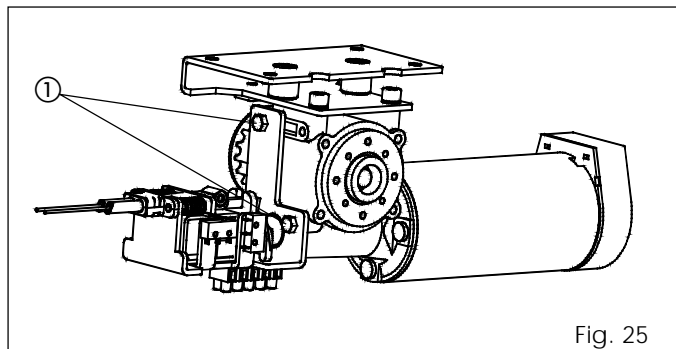

Fig. 25

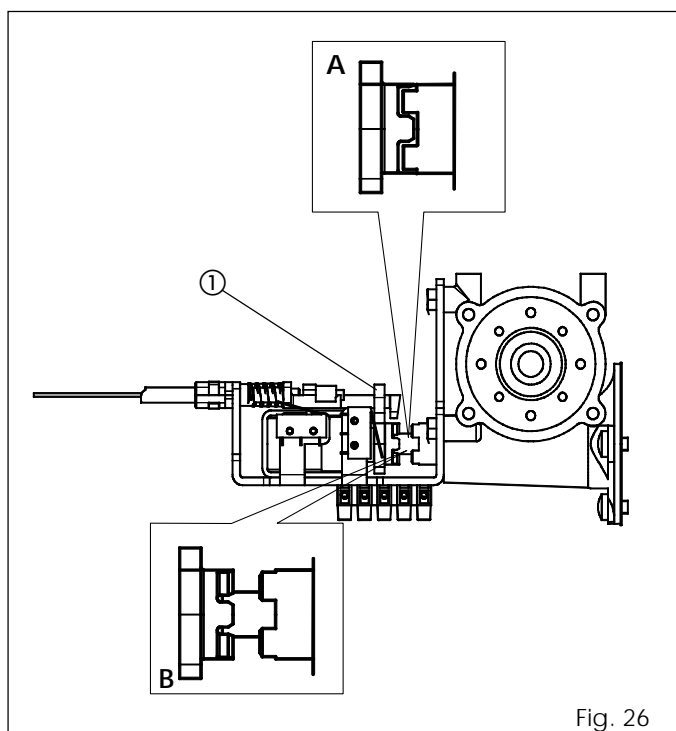

Fig. 26

If there is no play on the coupling, proceed as follows:

- Loosen the two screws (fig. 27 ref. ①) on both carriages.
- Slightly move the belt horizontally until the lever moves smoothly; tighten the screws on the carriages.

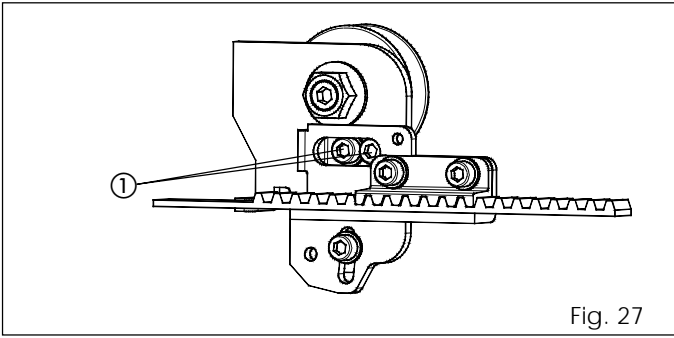

Fig. 27

12.1 Installation of internal release knob

- Assemble the release knob as indicated in fig. 28 ref. ①.
- Press the contrast washer until it fits in the release knob.
- Screw the adjuster, with the relevant lock nuts, on the internal part of the bracket (fig. 28 ref. ②).
- Fit the cable inside the adjuster, threading it through the washer and the release knob.
- Secure the steel cable with the cable gland and the appropriate screw (fig. 28 ref. ③).
- Pull the cable up to the cable gland stop inside the knob.
- Take the cable sheath against the adjuster (fig. 28 ref. ④).

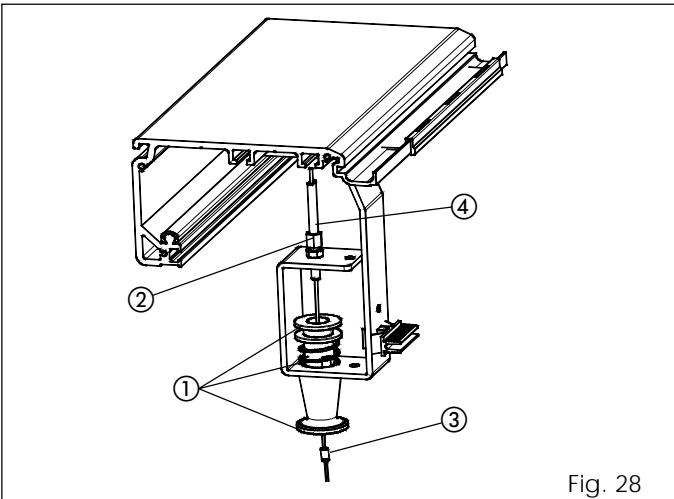

Fig. 28

12.2 Motor lock adjustment

- Fully screw the adjuster on the bracket.
- Pull the knob and rotate it through 90° so that it locks on the bracket.
- Thread the cable (fig. 29 ref. ①) inside part ②, leaving the sheath at its limit stop.
- Fit the cable on the terminal (fig. 29 ref. ③).
- Pull part ④ to its limit stop (compressing the springs) and tighten the screw of the terminal ③, thus securing the steel cable.
- Make sure that the motor lock coupling is clear of the motor shaft coupling (fig. 26 ref. B).
- If adjustments are required, turn the knob bracket adjuster.
- Release the knob rotating it through 90° and check if the release is efficient.

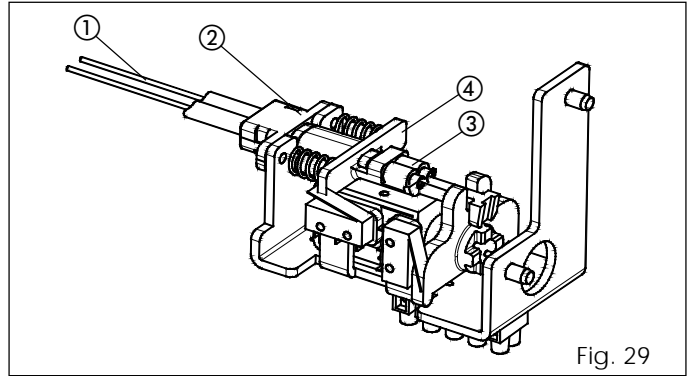

Fig. 29

13. FITTING THE HOUSING

- Fit three spacers (fig. 30 ref ①) on the outer edge of the support profile, positioning them at the ends and at the centre.

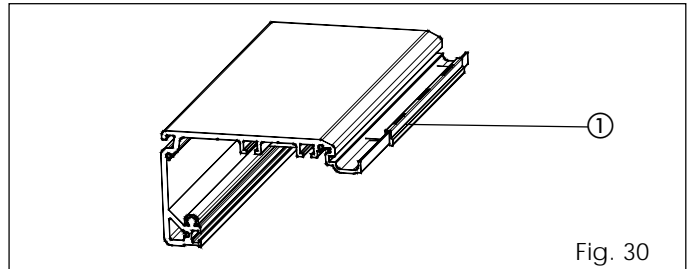

Fig. 30

- Lay the housing on the spacers.
- To keep the housing open, lift it and push it toward the profile until the metal projection fits into the profile seat (fig.31 ref. ①).
- Fasten the 'parachute' cables on the housing and on the housing fixing brackets as shown in fig. 31 ref. ②.
- The housing is secured on the brackets with the appropriate hooks (fig. 32).
- Break off the excess lower housing profile with a pair of pliers (fig. 32 rif. ①).

N.B.: To ensure correct closure of the housing, if using the internal release, shape the housing to the dimensions in fig. 33.

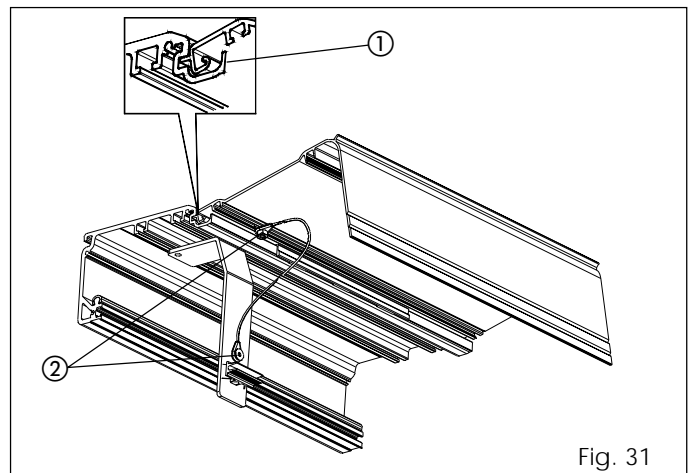

Fig. 31

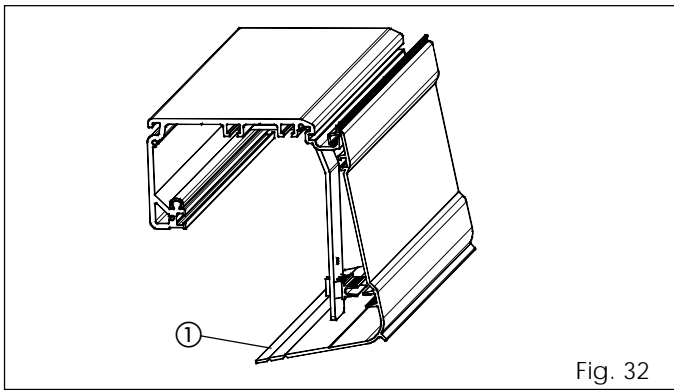

Fig. 32

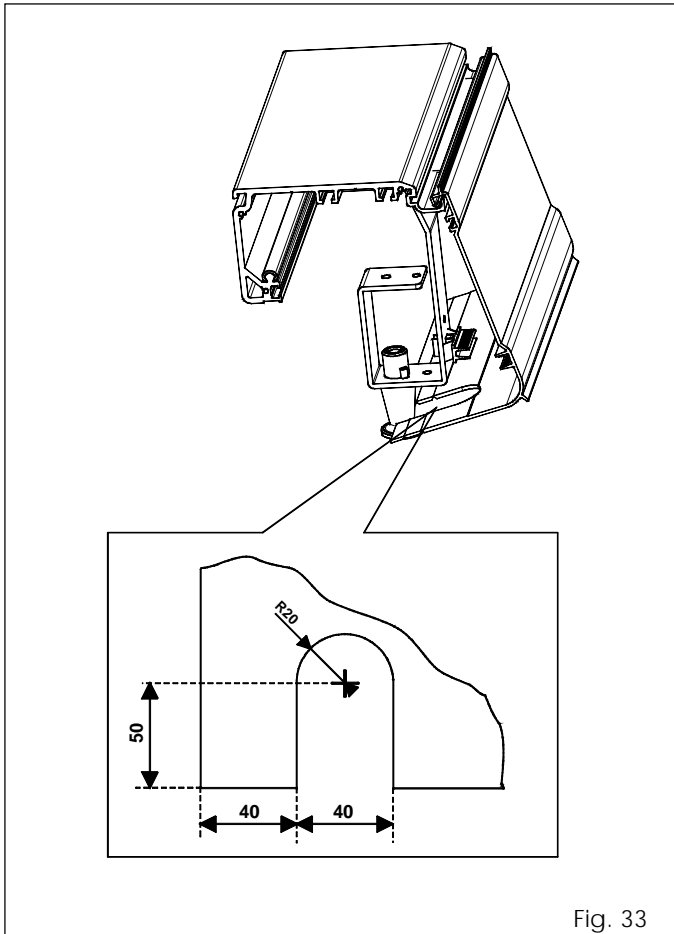

Fig. 33

14. INSTALLATION OF CABLE SLEEVES

Fit the supplied cable sleeves parallel to the profile (fig. 34 ref. ①) and then turn them by 90° to secure them (fig. 34 ref. ②).

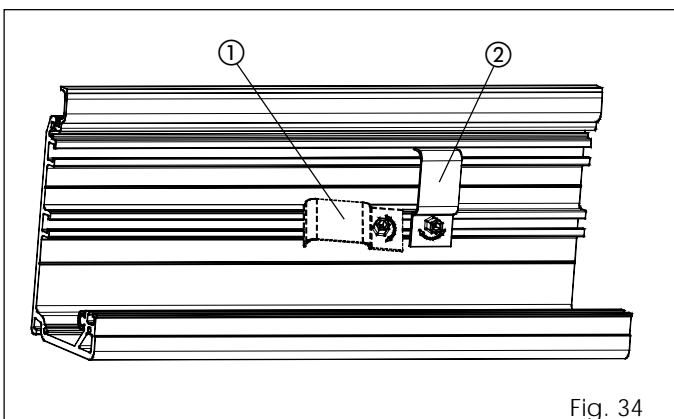

Fig. 34

15. INSTALLATION OF BUFFER BATTERIES

Fit the buffer batteries inside the transformer unit (fig. 35).

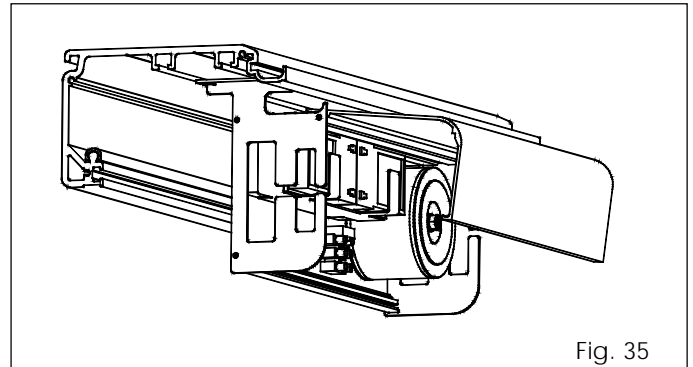

Fig. 35

16. INSTALLATION WITH GRIPPERS FOR GLASS LEAVES

To install with the glass leaves grippers, refer to the dimensions in figure. 36.

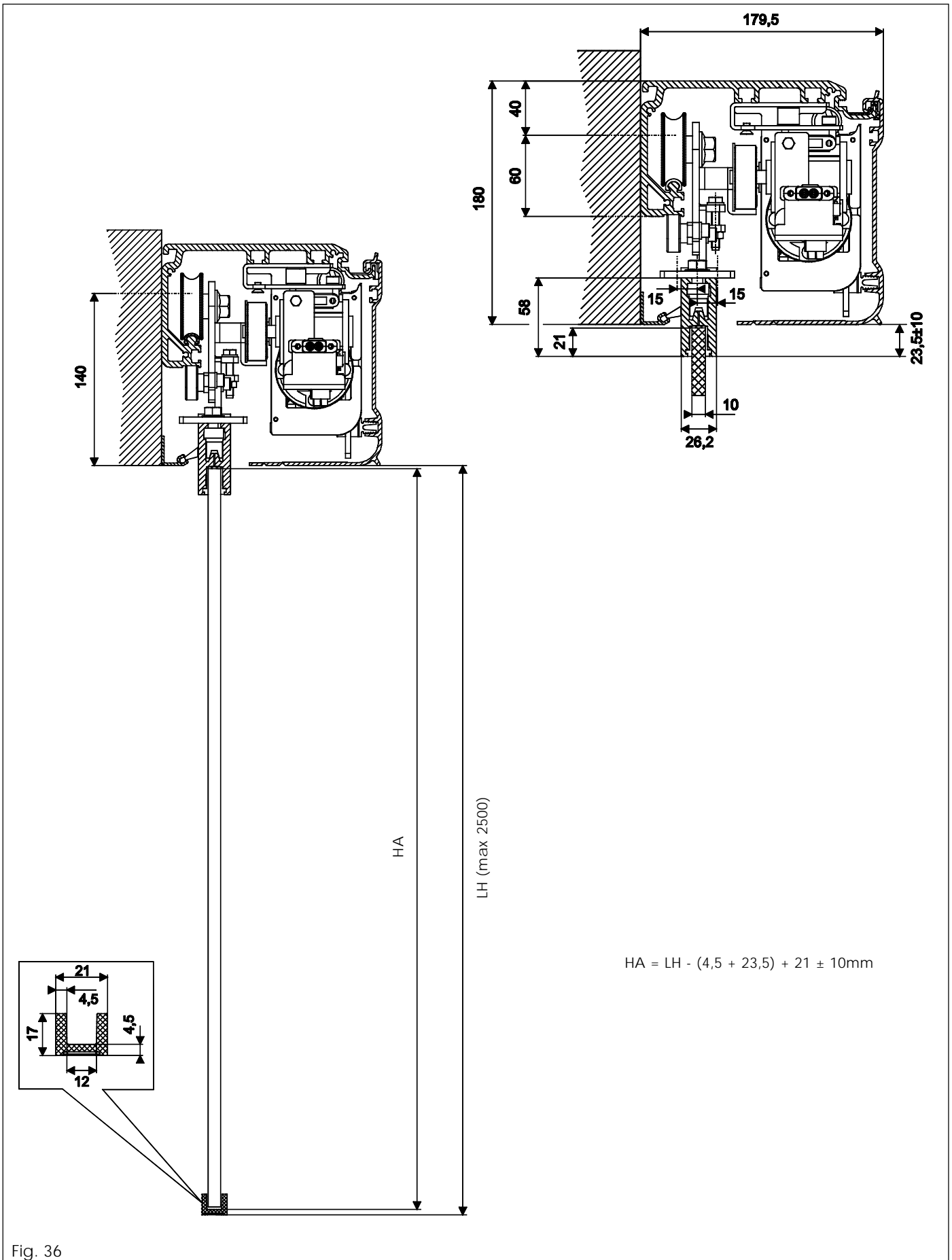

Fig. 36

17. START-UP

- To remove the protective cover of the SDM control unit, delicately obtain leverage with a screwdriver as shown in fig. 37.
 - To refit it, attach it on the top part and press as shown in fig. 38.
 - To remove the motor unit's cover, loosen the screws.
 - Manually check correct movement of the leaves and all moving elements.
 - Make/check all electrical connections on the SDM board of the power cables from the toroidal transformer, from the motor and from all accessories - routing the cables inside the pre-fitted cable sleeves.
 - Set motor direction of rotation according to type of door (refer to the instructions of the SDM board).
 - Check if a jumper is present on terminal board J7 of the SDM board (refer to the SDM board).
 - Connect the 230V power cables to the terminals inside the transformer unit (fig. 39 ref. ①).
- Note: a 1A time-delay fuse is also supplied to protect the transformer.
- Set automatic operating mode and execute setup.
 - Check the efficiency of all installed accessories, especially photocells and sensors.

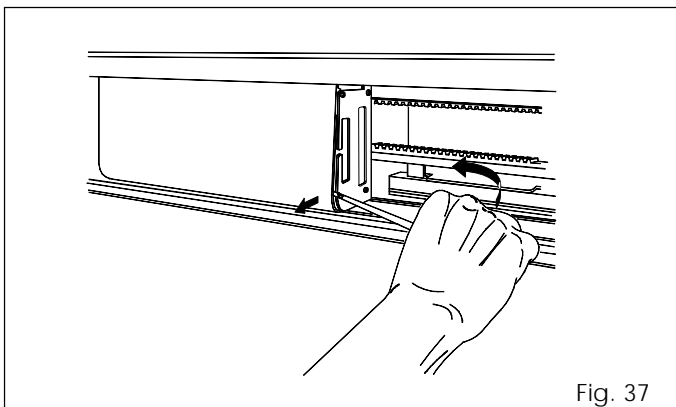

Fig. 37

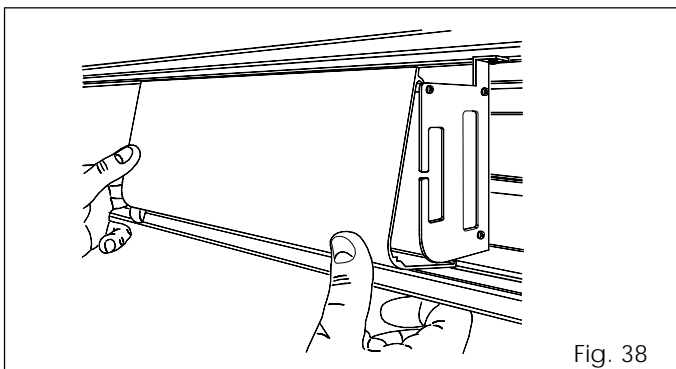

Fig. 38

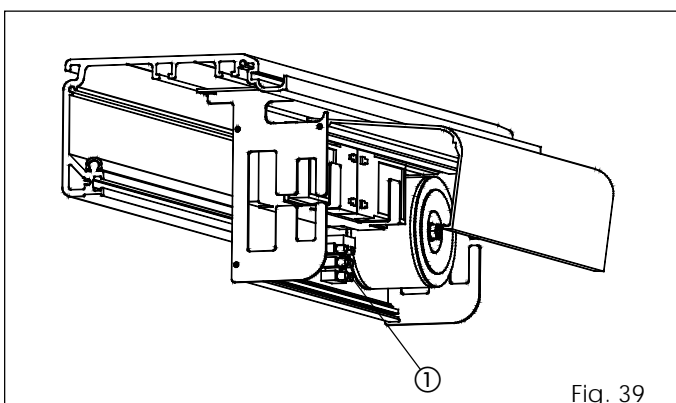
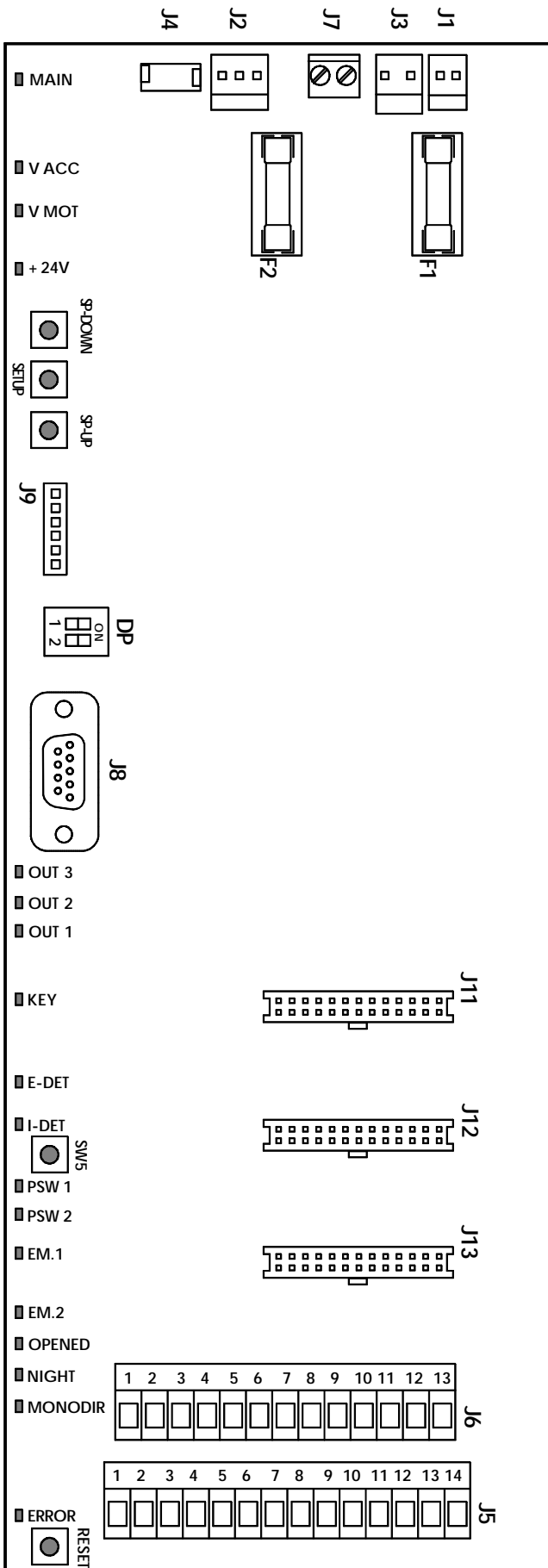

Fig. 39

940SDM CONTROL BOARD



LED	ON	OFF
MAIN	220V~ mains ON	220V~ mains OFF
V ACC	Vacc ON	Vacc OFF
V MOT	motor powered up	motor powered down
+ 24V	+ 24V ON	+ 24V OFF
OUT 3	OUT 3 contact closed	OUT 3 contact open
OUT 2	OUT 2 contact closed	OUT 2 contact open
OUT 1	OUT 1 contact closed	OUT 1 contact open
KEY	KEY input closed	KEY input open
E-DET	E-DET input closed	E-DET input open
I-DET	I-DET input closed	I-DET input open
PSW 1	PSW 1 input closed	PSW 1 input open
PSW 2	PSW 2 input closed	PSW 2 input open
EM.1	EMERG.1 input closed	EMERG.1 input open
EM.2	EMERG.2 input closed	EMERG.2 input open
OPENED	OPENED input closed	OPENED input open
NIGHT	NIGHT input closed	NIGHT input open
MONODIR	ONE WAY input closed	ONE WAY input open
ERROR	see table	
LED ERROR STATUS	MEANING	
OFF	normal operating status	
ON	Alarms n° 18,20,22,24: execute SETUP	
SLOW FLASHING	current alarm signalling	
FAST FLASHING	setup/reset in progress or during setup with the "kit elastic" activated	

PUSH-BUTTON	MEANING
RESET	executes reset
SW5	pulse on "internal sensor" input (I-DET)
SETUP	executes automatic setup
SP-DOWN	reduces closing speed
SP-UP	increases closing speed
CONNECTOR	MEANING
J1	connector to J2 of second motor board
J2	connector to J3 of second motor board
J3	motor quick-fit connector
J4	flat cable connector for encoder
J5	terminal board
J6	terminal board
J7	NOT AUS emergency stop (NC contact)
J8	RS232 serial port for PC connection
J9	connector to J5 of second motor board
J11-J12-J13	connectors for additional control boards
FUSE	MEANING
F1	fuse 5x20 T 6.3A/250V (motor protection)
F2	fuse 5x20 T 1A/250V (24V protection)
DP	ON
Dip n°1	motor rotation direction (see table)
Dip n°2	RS232 port set for S/W update
	OFF
	RS232 port set for PC connection

SECOND MOTOR CONTROL BOARD

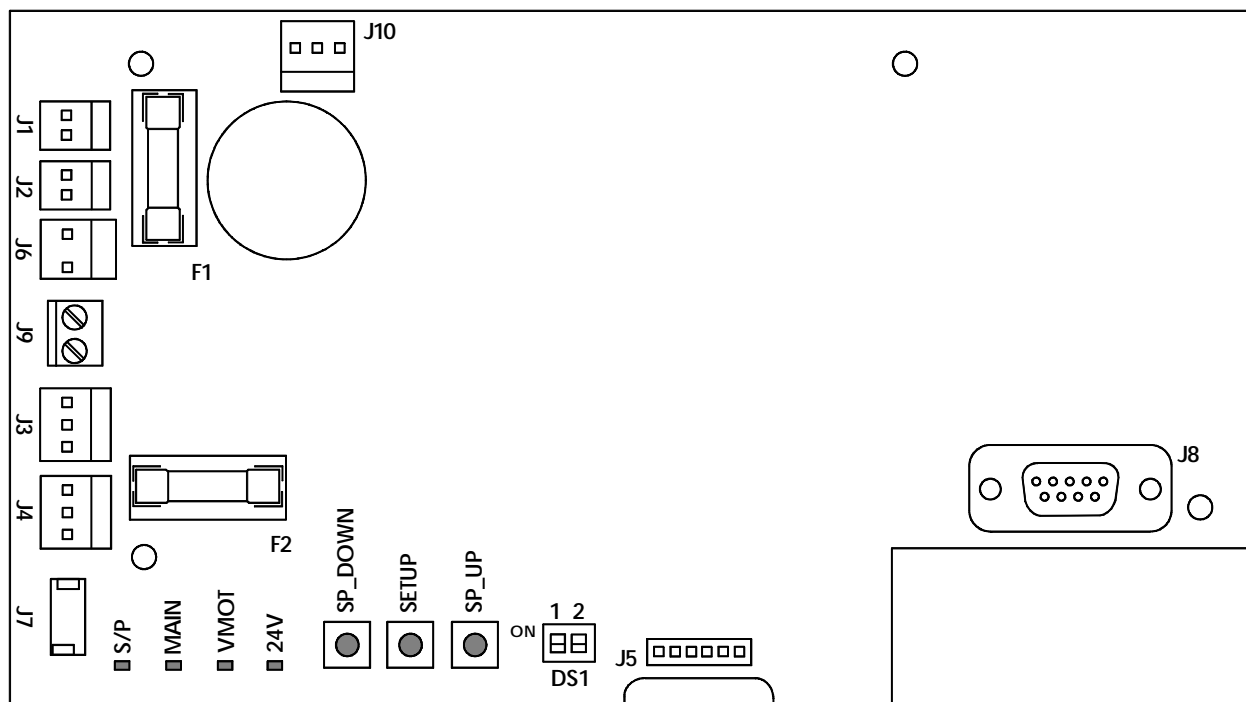

LED	ON	OFF
MAIN	220V~ mains ON	220V~ mains OFF
V MOT	motor powered up	motor powered down
24V	+ 24V ON	+ 24V OFF

PUSH-BUTTON	MEANING
SETUP	inactive
SP-DOWN	inactive
SP-UP	inactive

CONNECTOR	MEANING
J1	transformer 40V secondary winding
J2	connector to J1 of 940SDM
J3	connector to J2 of 940SDM
J4	transformer 24V secondary winding
J5	connector to J9 of 940SDM
J6	second motor quick-fit connector
J7	not used
J8	RS232 serial port for PC connection
J9	NOT AUS emergency stop (NC contact)
J10	connector to J3 of batteries board

DS1	MEANING
Dip n°1	to be always positioned to OFF
Dip n°2	posizionare sempre in OFF

FUSE	MEANING
F1	fuse 5x20 T 6.3A/250V (motor protection)
F2	fuse 5x20 T 1A/250V (24V protection)

S/P LED STATUS	MEANING
OFF	normal operating status
ON	no connecting to 940SDM board

INSTALLING SECOND MOTOR BOARD

The assembled 940 twin-motor doors are supplied with pre-wired second-motor board. For Kit doors, fit the second board using the spacers provided and positioning them on the 940SDM board to correspond to the holes as shown in fig. 1 rif. ①. Wire up the two units using the cables provided and following the diagram in fig. 2.

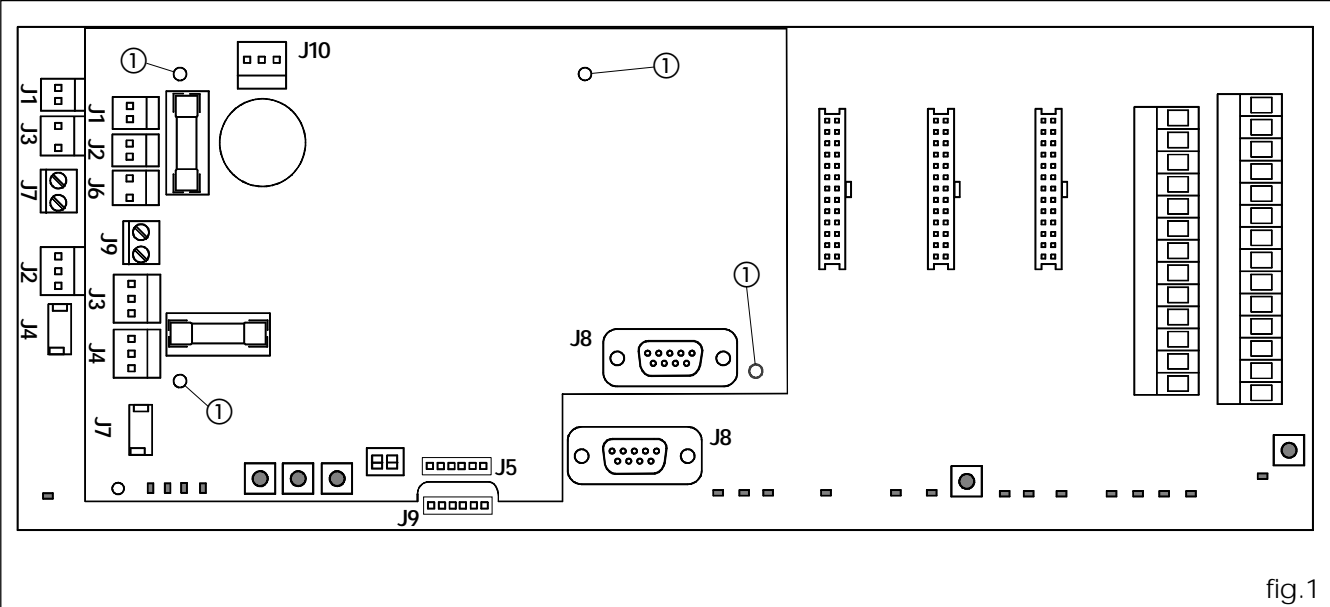

fig.1

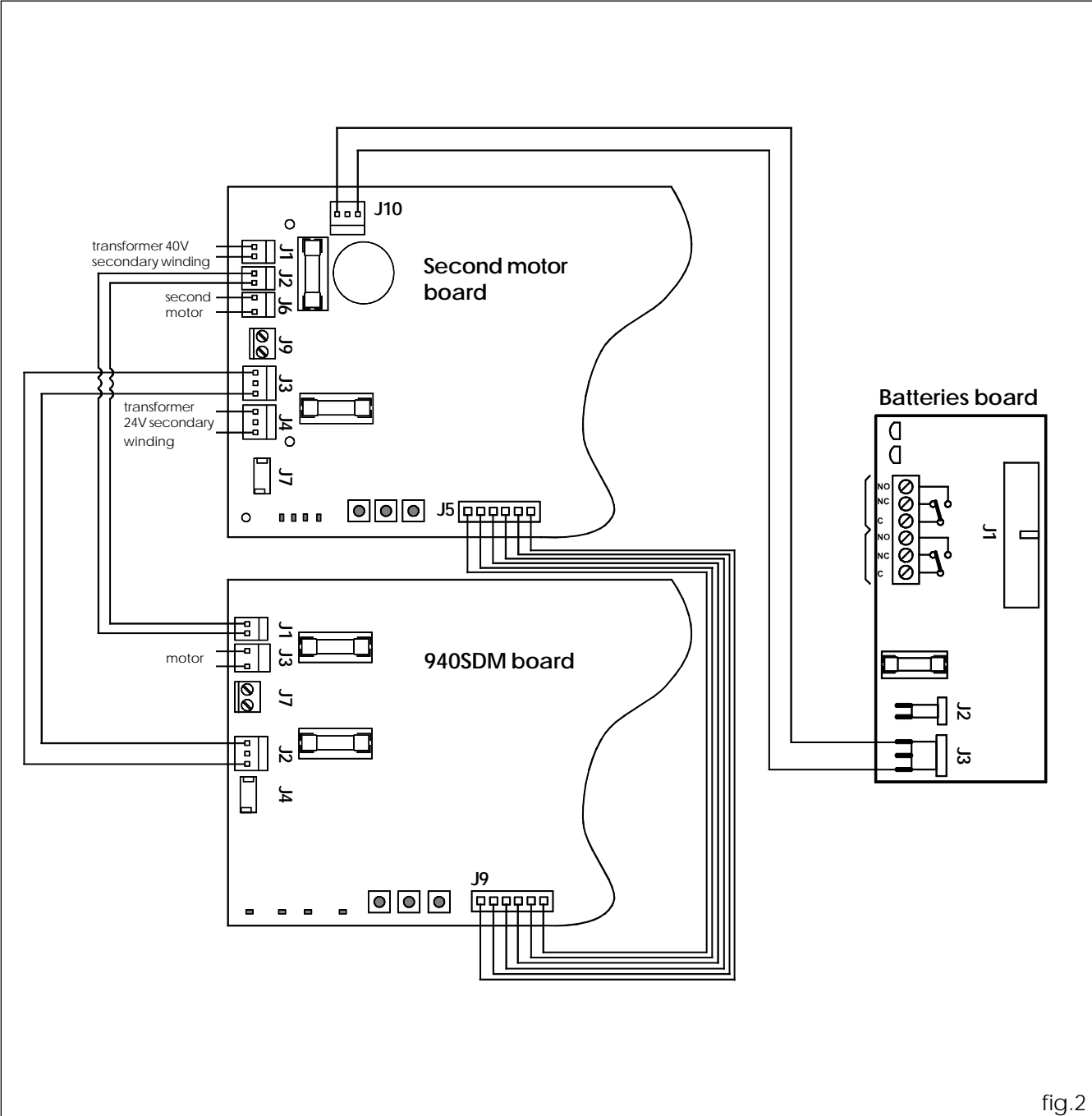
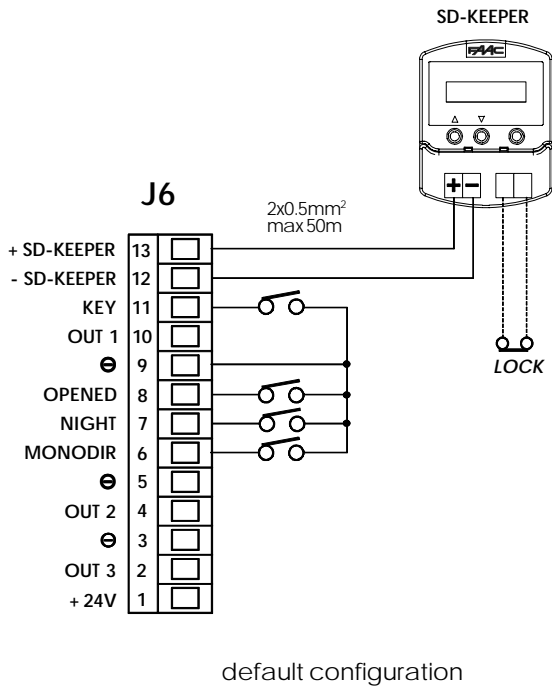
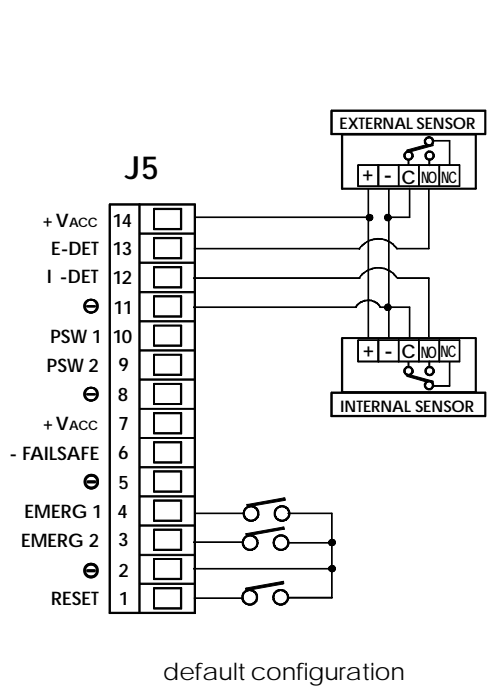

fig.2

TERMINAL BOARD J6



TERMINAL BOARD J5



NOTE: Photocell inputs in connection diagrams are considered NC contacts (default configuration).

CONNECTION OF PHOTOCELLS WITH FAILSAFE DISABLED (DEFAULT)

no photocell

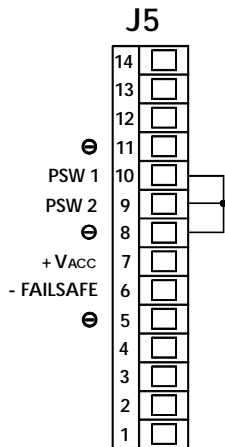

1 pair of photocells

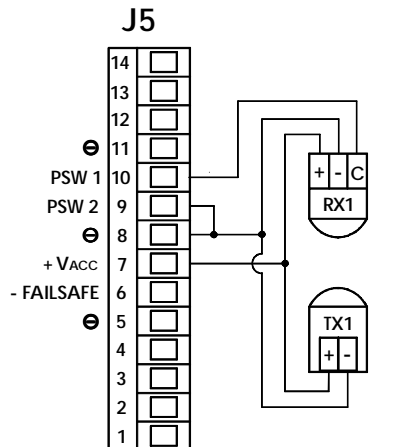

2 pairs of photocells

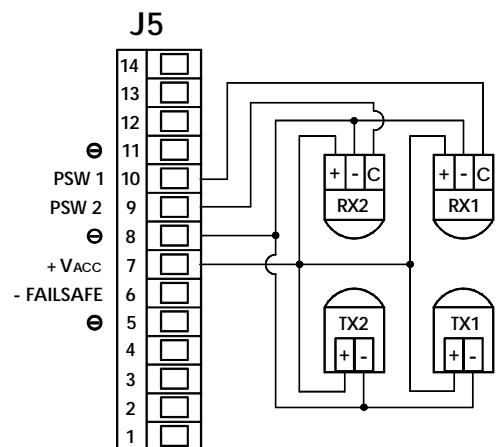

CONNECTION OF PHOTOCELLS WITH FAILSAFE ENABLED

no photocell

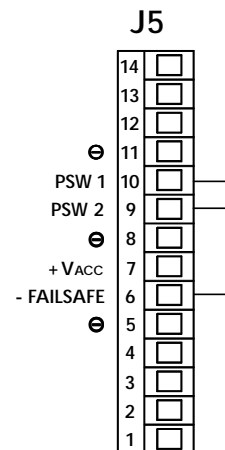

1 pair of photocells

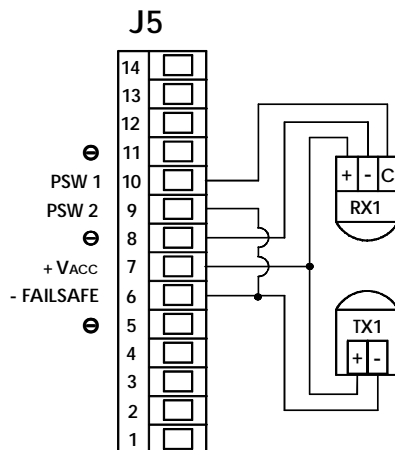

2 pairs of photocells

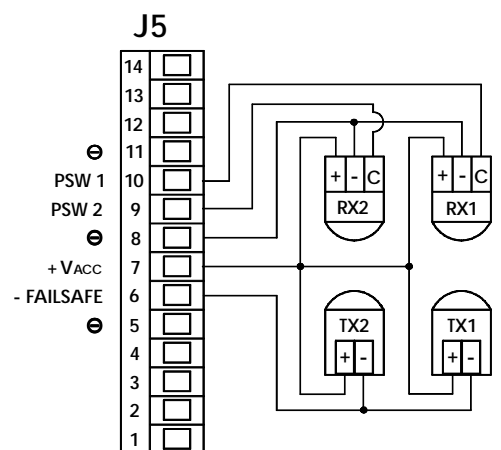

DESCRIPTION OF TERMINALS

TERMINAL BOARD J5

- 1 RESET (NO contact)**
Contact closure executes the Reset procedure. Reset is the function for restoring normal operating conditions after some types of alarm.
- 2-5-8-11 - (COM)**
Negative for powering accessories (+24V and +Vacc) and common for contacts
- 3 EMERG2 (NO default contact)**
Emergency command:
in the standard setting, activation causes the door to open (the door stays open for as long as the command is activated).
By using SD-Keeper+Display, you can program the operation of this input differently (see programming instructions).
- 4 EMERG1 (NO default contact)**
Emergency command:
in the standard setting, activation causes the door to stop (the door stays in stop status for as long as the command is activated).
By using SD-Keeper+Display, you can program the operation of this input differently (see programming instructions).
- 6 -FAILSAFE**
Negative for powering photocell projectors when the FAILSAFE function is activated (programmable from SD-Keeper+Display).
- 7-14 +Vacc**
+24V power supply for accessories.
The total maximum load of the accessories connected to the "+Vacc" and "+24V" inputs, must not exceed 700mA.
- ➔ While operating on the battery in the absence of mains power, when the battery charge drops to a critical level, Vacc is interrupted for energy saving purposes.
- 9 PSW2 (NC default contact)**
Input of 2nd safety photocell
By using SD-Keeper+Display, you can :
- program the NO contact,
- cut out this input if there are no photocells or if there is only one photocell (which must therefore be connected to the PSW1 input).
For the effects the tripped photocell has on this input, see PSW1.
- 10 PSW1 (NC default contact)**
Input of 1st safety photocell
By using SD-Keeper+Display, you can :
- program the NO contact,
- cut out this input if there are no photocells.
Following intervention by the photocell connected to this input, the door behaves as follows:
OPENING: no effect
PAUSE: pause time re-counted
CLOSING: reverses immediately
- 12 I-DET (NO default contact)**
Internal sensor input.
By using SD-Keeper+Display, you can program the NC contact.
- 13 E-DET (NO default contact)**
External sensor input.
By using SD-Keeper+Display, you can program the NC contact.

J6 TERMINAL BOARD

- 1 +24V**
+24V power supply for accessories.
The total maximum load of the accessories connected to the "+Vacc" and "+24V" inputs, must not exceed 700mA.
- 2 OUT 3 (default "door not close")**
Open-collector (negative) output (100mA).
In the standard setting, this output is active for as long as the door is not closed.
By using SD-Keeper+Display, you can program the operation of this output differently (see programming instructions).
- 3-5-9 - (COM)**
Negative for powering accessories (+24V and +Vacc) and common for contacts.
- 4 OUT 2 (default : "night courtesy light")**
Open-collector (negative) output (100mA).
In the standard setting, this output is activated for 60 sec. when the door is commanded to open in NIGHT mode.
By using SD-Keeper+Display, you can program the operation of this output differently (see programming instructions).
- 6 MONODIR (NO contact)**
If the SD-Keeper is not installed, closing this contact activates the "ONE WAY" function.
- 7 NIGHT (NO contact)**
If the SD-Keeper is not installed, closing this contact activates the "NIGHT" function.
- 8 OPENED (NO contact)**
If the SD-Keeper is not installed, closing this contact activates the "DOOR OPEN" function.
- 10 OUT 1 ("gong" default)**
Open-collector (negative) output (100mA).
In the standard setting, this input is active, while the photocells are covered, for 1 sec. at 0.5 sec. intervals until disengaged.
By using SD-Keeper+Display, you can program the operation of this output differently (see programming instructions).
- 11 KEY (NO default contact)**
Key command:
activation causes the door to open and then re-close after night pause time elapses.
By using SD-Keeper+Display, you can program the NC contact.
- 12-13 SD-KEEPER**
SD-Keeper connection terminals (cable: 2x0.5mm² max 50m).
➔ Observe indicated polarity.

TERMINAL BOARD J7

- NOT AUS (NC contact)**
Contact for the emergency push-button (NC) which cuts power to the motor.
➔ If not used, jumper the terminals with a 0.5mm² cable.

MOTOR ROTATION DIRECTION

Set dip-switch n°1 as follows:

DOOR MODEL	DIP-SWITCH N°1
2 LEAVES	OFF
1 LEFT OPENING LEAF	ON
1 RIGHT OPENING LEAF	OFF

- ➔ The closing direction is established by watching the automated system head profile from the front and:
- in the case of a double leaf, the LEFT leaf connected to the top section of the belt.
- in the case of a single leaf, the leaf connected to the top section of the belt.

START-UP

The first time the door is powered, the 940SDM control board automatically executes a setup procedure and loads all the standard configuration settings.

STANDARD CONFIGURATION

The standard configuration is as follows:

- "AUTOMATIC" - "TOTAL" - "TWO-WAY"; operating function;
- maximum OPENING SPEED (level 10);
- CLOSING SPEED level 3;
- EMERG1 emergency input configured as a "no memory" NO contact, i.e. when activated, it causes the movement to stop and the door remains open in stop status for as long as the contact is maintained;
- EMERG2 emergency input configured as a "no memory" NO contact, i.e. when activated, it causes opening at normal speed and the door remains open for as long as the contact is maintained;
- two photocells with NC contact are supplied, to be connected to the PSW1 and PSW2 contacts (if one or both are not installed, jumper connections must be made according to the diagram);
- FAILSAFE disabled;
- ANTI-INTRUDER function active;
- PAUSE time 2 sec.;
- NIGHT PAUSE time 8 sec.;
- KIT LOCK enabled in standard mode (locks in NIGHT mode only);
- SURVEILLANCE KIT on disabled lock;
- BATTERY KIT not enabled;
- OUT1 output with GONG function;
- OUT2 output with LIGHT function;
- OUT3 output with DOOR NOT CLOSE function;
- PARTIAL OPENING set at 50%;
- no anticipated DECELERATION during opening and closing;
- Low DECELERATION SPEED;
- Standard OBSTACLE DETECTION: if an obstacle is recognised at opening or closing, the door reverses and continuously attempts to move until the obstacle is removed, without generating an alarm signal;
- two SENSORS with NO contact are provided (one internal, the other external);
- NO type KEY contact;
- INTERLOCK function not activated;
- ANTI-PANIC KIT WITH ELASTIC not enabled;
- TIMER not activated.

IMPORTANT:

The standard configuration, particularly for the set speed levels, does not guarantee compliance with standards prEN12650-1 and prEN12650-2, specified for doors distributed and installed in the European Union.

PHOTOCELLS

The following configurations are possible:

-NO PHOTOCCELL

- In the standard configuration, PSW1 and PSW2 inputs must be jumper connected to the FAILSAFE terminal;
- for the SD-Keeper+Display, as an alternative, the PSW1 and PSW2 inputs can be disabled, thus avoiding the jumpers.

-1 PHOTOCCELL

- In the standard configuration, the photocell must be connected to the PSW1 input, while PSW2 must be jumper connected to the FAILSAFE terminal;
- for the SD-Keeper+Display, as an alternative, one photocell only can be set (connecting it to the PSW1 input as usual), thus disabling the PSW2 input and avoiding

the jumper (see the SD-Keeper programming instructions).

-2 PHOTOCCELLS

- connect the photocells to the PSW1 and PSW2 inputs.

Programming with the SD-Keeper+Display makes it possible to (see programming instructions):

- select the number of connected photocells (2,1,0);
- select the type of contact (NO/NC) of the PSW1 and PSW2 inputs;
- enable/disable the failsafe.

SETUP

The following parameters are checked and adjusted during the Setup cycle:

- measurement of masses and friction, setting of speeds, plus optimal acceleration and deceleration;
- acquisition of open and closed door positions;
- self-setting of the anti-crushing system at opening/closing according to selected speeds.

During Setup, the ERROR LED flashes rapidly and goes off at the end of the process if correctly executed.

Any faults are signalled by the ERROR LED and by the diagnostics via SD-Keeper.

Detection of serious faults (e.g. insufficient or excessive leaf travel, too much friction, motor malfunctions) causes the ERROR LED to light up steadily.

Subsequent variations of closing speed (by the push-buttons on the control board or SD-Keeper+Display) are signalled by a slowly flashing ERROR LED and by ALARM 1; in this case, a new Setup is necessary to ensure that the electronic anti-crushing device operates correctly.

To activate a new Setup procedure, press the SETUP push-button on the control board; Setup can also be started by a combination of push-buttons on SD-Keeper (see relevant instructions).

The following are the situations in which, if required, the Setup cycle is not executed, and the door stays in shut-down state, generating an alarm signal (slowly flashing ERROR LED and ALARM 15 on SD-Keeper):

- door powered by battery;
- NIGHT operating function selected;
- MANUAL operating function selected;
- DOOR OPEN operating function selected;
- an emergency input is active;
- photocells engaged;
- no power supplied to motor.

When the cause has been eliminated, the Setup starts automatically.

RESET

Whenever the automated system is powered, the door executes a Reset cycle during which:

- the door's travel limit positions are sought;
- any alarm signals are reset.

To activate a new Reset procedure, press the RESET push-button on the control board; Reset can also be started by a combination of push-buttons on SD-Keeper (see relevant instructions).

If a Reset is commanded while the door is in "Manual" mode, it is executed when this operating function is exited.

In the "Night" operating function, Reset consists of a slow closing movement, whereas it is normally a slow opening movement.

During Reset, the ERROR LED flashes rapidly.

The reset procedure is necessary following the occurrence of certain conditions causing the door to stop operating:

- after an obstacle is detected on 3 successive occasions during closing/opening when the function STANDARD OBSTACLE DETECTION (ALARM 8 or ALARM 9) has been activated;
- after a "with memory"-configured emergency command has been activated (see programming instructions), (ALARM 6 or ALARM 7);
- if, when using a kit lock, an opening malfunction is detected on the kit.

SPEED CHANGES

There are 10 speed adjustment levels for opening and closing.

Level 10 refers to the maximum speed permitted by door weight, whereas level 1 refers to the corresponding minimum speed.

CLOSING speed can be adjusted by two push-buttons on the 940SDM control board (SP-UP and SP-DOWN) if the SD-Keeper is NOT present.

By using SD-Keeper+Display, you can change both closing and opening speed.

Whenever closing speed is changed, the ERROR LED flashes slowly and the SD-Keeper shows ALARM 1 to report the need to execute a new Setup, in order to ensure the electronic anti-crushing device operates correctly.

BEHAVIOUR UNDER DIFFERENT OPERATING FUNCTIONS

OPERATING FUNCTION	DOOR STATUS	INTERNAL SENSOR (I-DET)	EXTERNAL SENSOR (E-DET)	KEY	EMERGENCY OPENING (EMERG 2) (2)	EMERGENCY CLOSING (2)
MANUAL	IN ANY POSITION	no effect	no effect	no effect	no effect	no effect
TOTALLY OPEN	OPEN	no effect	no effect	no effect	no effect	immediate closing
TOTAL AUTOMATIC TWO-WAY	OPEN	restarts pause time count	restarts pause time count	starts night pause time count	starts pause time count	immediate closing
	CLOSED	total opening and re-closing after pause time	total opening and re-closing after pause time	total opening and re-closing after night pause time	total opening	no effect
PARTIAL AUTOMATIC TWO-WAY	PARTIALLY OPEN	restarts pause time count	restarts pause time count	starts night pause time count	total opening	immediate closing
	CLOSED	partial opening and re-closing after pause time	partial opening and re-closing after pause time	partial opening and re-closing after night pause time	total opening	no effect
TOTAL AUTOMATIC ONE WAY	OPEN	restarts pause time count	no effect	starts night pause time count	starts pause time count	immediate closing
	CLOSED	total opening and re-closing after pause time	no effect	total opening and re-closing after night pause time	total opening	no effect
PARTIAL AUTOMATIC ONE WAY	PARTIALLY OPEN	restarts pause time count	no effect	starts night pause time count	total opening	immediate closing
	CLOSED	partial opening and re-closing after pause time	no effect	partial opening and re-closing after night pause time	total opening	no effect
TOTAL NIGHT	CLOSED	no effect	no effect	(1) total opening and re-closing after night pause time	total opening	no effect
PARTIAL NIGHT	CLOSED	no effect	no effect	(1) partial opening and re-closing after night pause time	total opening	no effect

- (1) During standard operation with battery in the "Night" operating mode, opening is performed by activating the command key for 3 seconds.
- (2) Emerg1 and Emerg 2 inputs can be programmed with SD-Keeper+Display to obtain:
 - emergency opening;
 - emergency closing;
 - stop.
 Furthermore, command activation can be programmed:
 - with no memory (when the command is de-activated, the door resumes normal operation);
 - with memory (when the command is de-activated, a Reset is necessary to restore normal operation).

This is the default configuration:

Emerg1 ---> Stop/no memory

A pulse (function not shown in the table) causes immediate stop followed by slow re-closing after pause time (night pause time if the Night operating function was set).

Emerg2 ---> Emergency opening/no memory:

A pulse causes opening followed by re-closing after pause time.

Emergency commands have priority over all others.

SD-KEEPER PROGRAMMING UNIT

SD-Keeper is used for selecting operational functions, as well as adjusting and programming the 940 series automated doors.

It is divided into two parts: a fixed part used for selecting the operating functions by means of push-buttons and relevant signalling LEDs (fig. 3 ref. A), and a pull-out part with LCD display to access complete programming (fig. 3 ref. B).

The SD-Keeper display can be used as a temporary programming unit: after all programming and adjustments have been carried out, it can be fully removed because the settings remain stored on the 940SDM control board. When the display is removed, a cover is provided (fig. 3 ref. C).

SD-Keeper can be disabled by a combination of keys (see the special LOCK function) or by internally fitting a jumper by means of a switch (fig. 4 ref. LOCK).

FITTING

Refer to fig.4 for an exploded view of fitting. Let cable route through point A or B according to the cable position needs.

CONNECTIONS

Connect SD-Keeper to the 940SDM control board with the following cable: 2x0.5mm² max 50m (fig. 4).

If a jumper is closed between two terminals as shown in fig. 4 (LOCK), all keys on the programmer are disabled.

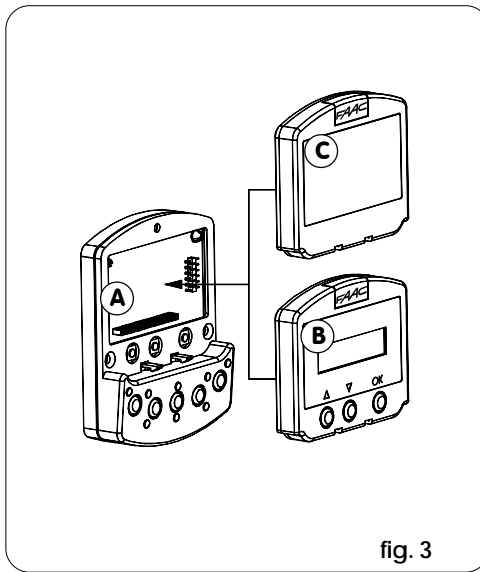

fig. 3

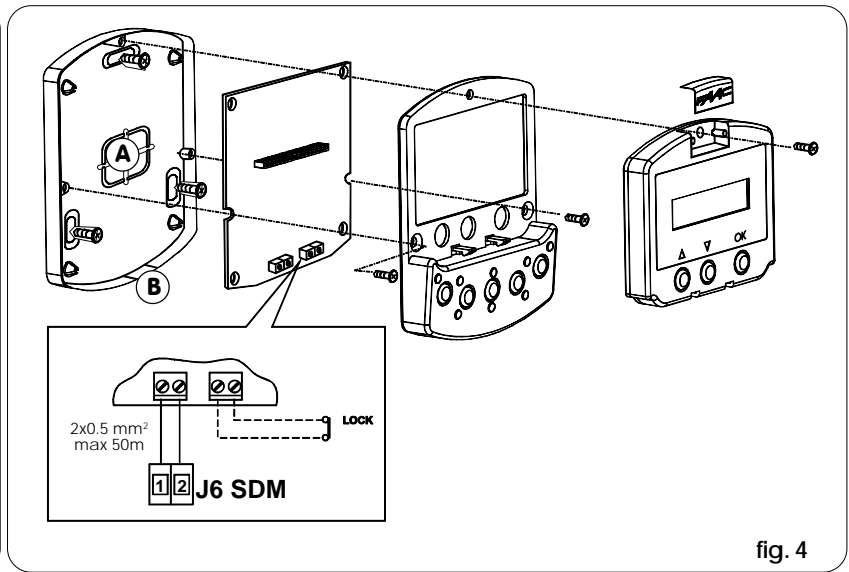

fig. 4

DIAGNOSTICS

SD-Keeper (also without display) has a diagnostic function which, in case of an alarm, interrupts normal display of the function every 2 seconds in order to show the fault status for 1 second by a combination of flashing LEDs.

Consult fig. 5 and table 1 to identify the type of alarm by interpreting the flashing LEDs.

➔ If there are several simultaneous faults, the first to be detected is shown.

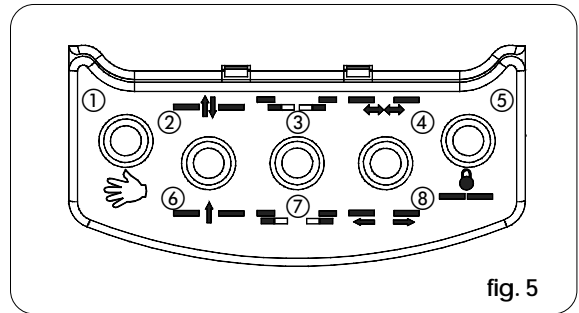

fig. 5

Tab.1 DIAGNOSTICS		Led							
DESCRIPTION	MEANING	①	②	③	④	⑤	⑥	⑦	⑧
ENERGY SAV.	Operating on low battery consumption	○	●	○	○	○	○	○	○
1 SPEED CHANGES	Speed changed, new setup required	○	○	○	○	○	○	○	●
2 BAT. OPERATION	Door operating on battery	○	○	●	○	○	○	○	○
3 FORCED OPEN	Door forced opening in progress.	○	○	●	○	○	○	○	○
4 FLAT BATTERY	Battery discharged: emergency movement not guaranteed	○	○	○	○	○	○	○	○
6 EMERG 2 ON	Emergency 2 input active	○	○	●	●	○	○	○	○
7 EMERG 1 ON	Emergency 1 input active	○	○	●	●	○	○	○	○
8 OBST.IN OPEN.	Opening obstacle detected 3 successive times; Reset necessary to restore operation.	○	○	○	○	○	○	○	○
9 OBST.IN CLOS.	Closing obstacle detected 3 successive times; Reset necessary to restore operation	○	○	○	○	○	○	○	○
10	Lock locked in closed position	○	○	○	○	○	○	○	○
11	Lock locked in open position (with surveillance kit only)	○	○	○	○	○	○	○	○
12	Incorrect power supply to motor (VMOT absent)	○	○	○	○	○	○	○	○
13	Photocell 2 faulty (PSW2 input)	○	○	○	○	○	○	○	○
14	Photocell 1 faulty (PSW1 input)	○	○	○	○	○	○	○	○
15	Setup not possible	○	○	○	○	○	○	○	○
18	Initialisation process not possible on motor: leaf stroke too long	○	○	○	○	○	○	○	○
20	Initialisation process not possible on motor: insufficient leaf stroke	○	○	○	○	○	○	○	○
22	Initialisation process not possible on motor: too much friction or leaf too heavy	○	○	○	○	○	○	○	○
24	Motor failure	○	○	○	○	○	○	○	○
25	940SDM control board faulty	○	○	○	○	○	○	○	○

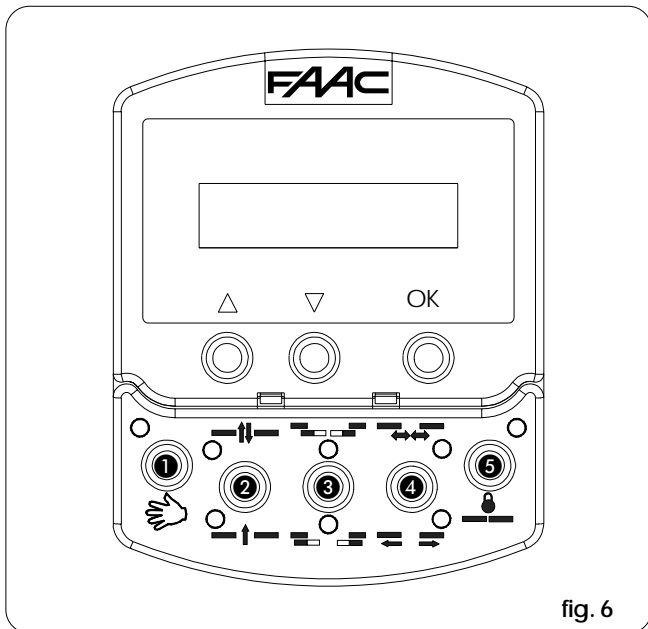

fig. 6

OPERATING FUNCTIONS

Selection is performed by pressing the keys on the fixed part of the programmer - the function is indicated by the relevant LED lighting up.

Note: when the "Night" or "Manual" modes have been set, the relevant selection keys must be pressed to exit the modes.

MANUAL

The sliding leaves are free and can be activated manually.

TWO-WAY

Pedestrian transit is possible in both directions; the inside and outside radars are enabled.

ONE WAY

Pedestrian transit is possible in one direction only; the external radar is disabled.

PARTIAL OPENING

The door opens only partially (standard: 50%)
Partial opening can be adjusted in range from 10% to 90% of total.

TOTAL OPENING

The door opens completely.

AUTOMATIC

The door opens (partially or totally) and then re-closes after the set pause time (standard: 2 sec.).
Adjusting range of pause time: 0 to 90 sec.

DOOR OPEN

The door opens and stays open.

NIGHT

The door closes and the lock (if present) is activated. The internal and external radars are disabled.
The Key command causes the door to open and re-close after night pause time elapses (standard: 8 sec).
Adjusting range of night pause time : 0 to 240 sec.
To obtain partial opening in this mode, before selecting the "Night" function, activate the "Partial Opening" function .

①		MANUAL
②		TWO-WAY
		ONE WAY
③		PARTIAL OPENING
		TOTAL OPENING
④		AUTOMATIC
		DOOR OPEN
⑤		NIGHT

SPECIAL FUNCTIONS

SETUP

Setup is the door initialisation function during which parameters are self-learned.

To activate, simultaneously press keys ① and ⑤ for 5 sec.

RESET

Reset is the function for restoring normal operating conditions after some types of alarm have been signalled.

To activate, simultaneously press keys ② and ③.

LOCK

When active, the Lock function disables SD-Keeper.

To activate (and de-activate), simultaneously press keys ③ and ④ for 5 sec.

BATTERY INSERTION/CHANGE

To keep the clock inside SD-Keeper active even in the event of a power cut, a 3V model CR1216 lithium battery is provided.

To insert or change the battery, find the compartment on the printed circuit (fig. 7) and observe the indicated polarity.

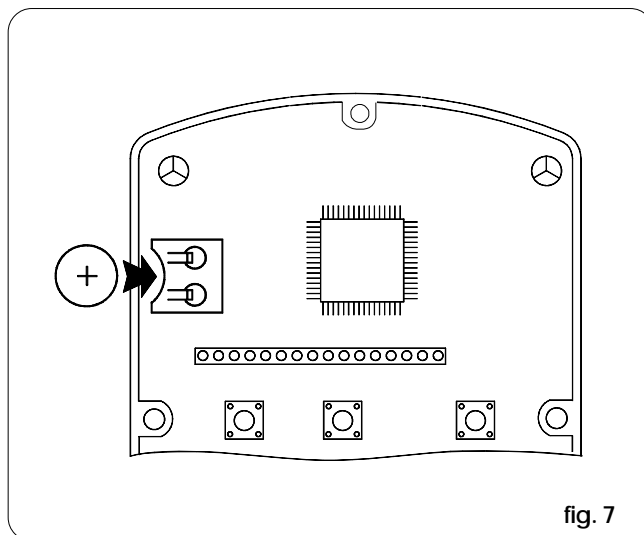

fig. 7

FLOW-CHART SD-KEEPER

To access programming while the standard view is shown on the display, press any of keys Δ or ∇ . Programming is subdivided into main menus (see box) split into subjects.

After selecting the menu with keys Δ or ∇ , to access it press OK.

Each menu is, in turn, subdivided into sub-menus at different parameter setting levels.

Use keys Δ or ∇ to select (sub-menu or parameter) and confirm with the OK key.

An asterisk on the display indicates the currently active setting.

To exit programming, select the "exit" function at each level. Otherwise, after about 2 minutes, the display automatically returns to standard view.

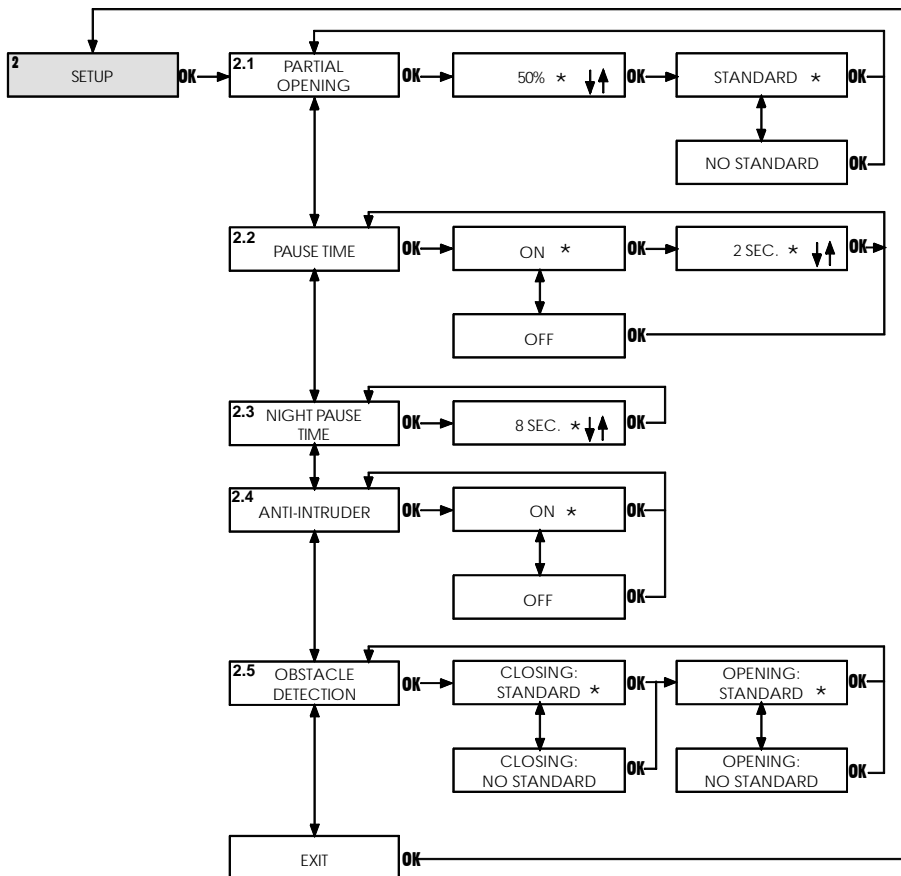
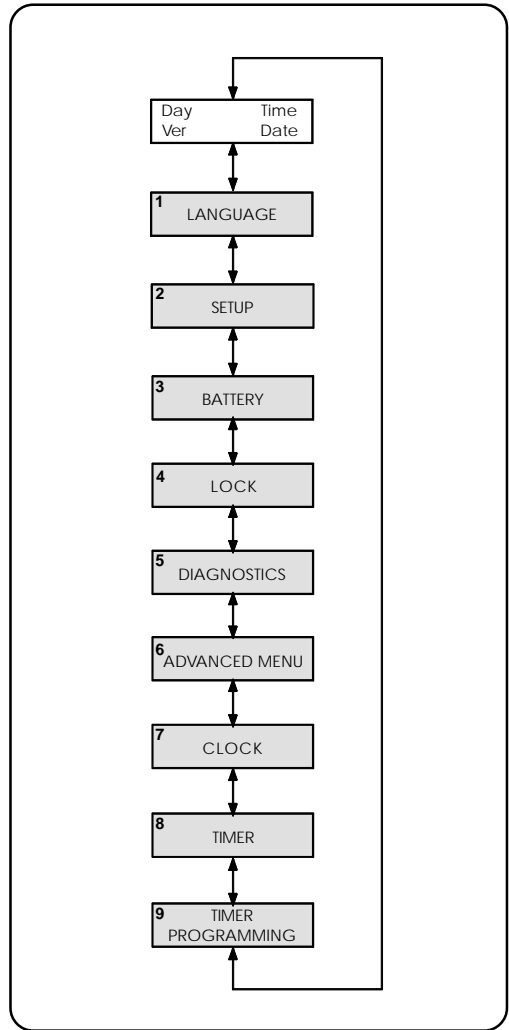
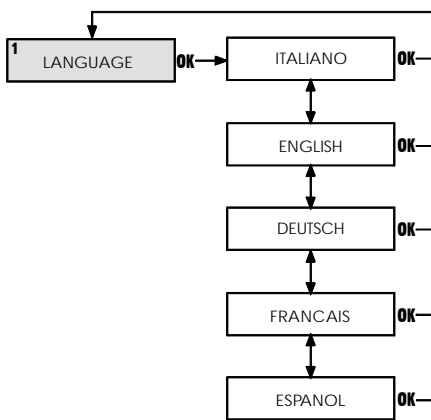

FLOW-CHART SD-KEEPER

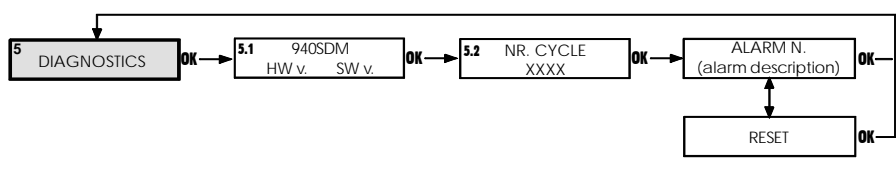
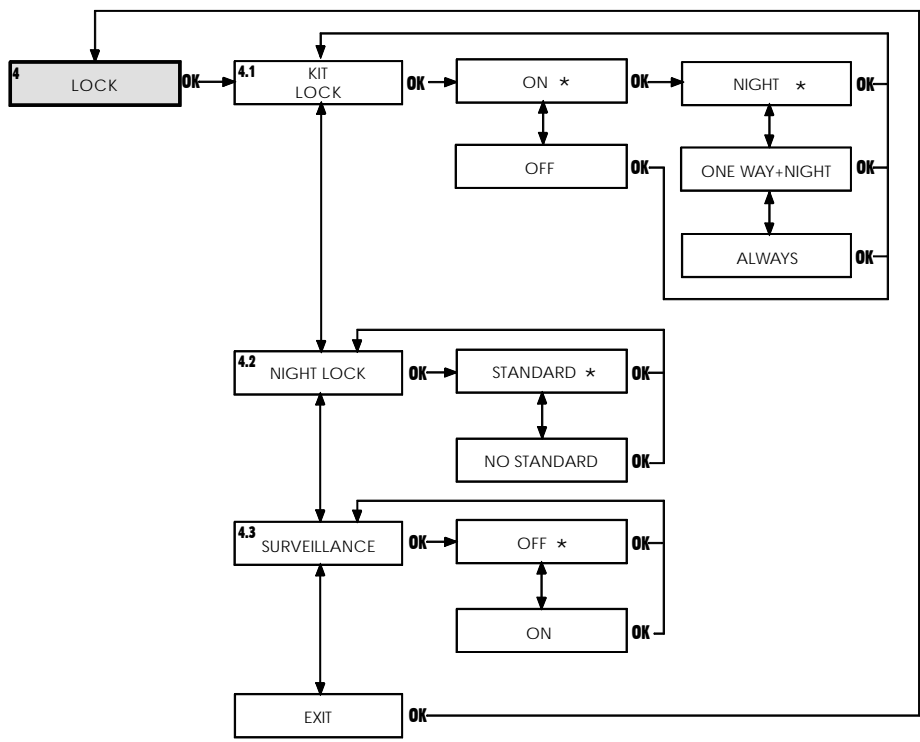
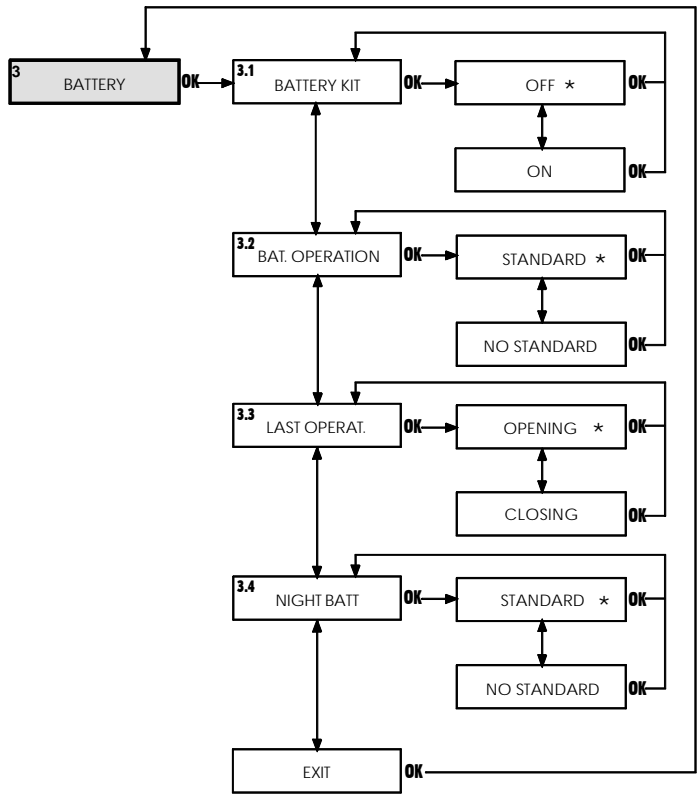

FLOW-CHART SD-KEEPER

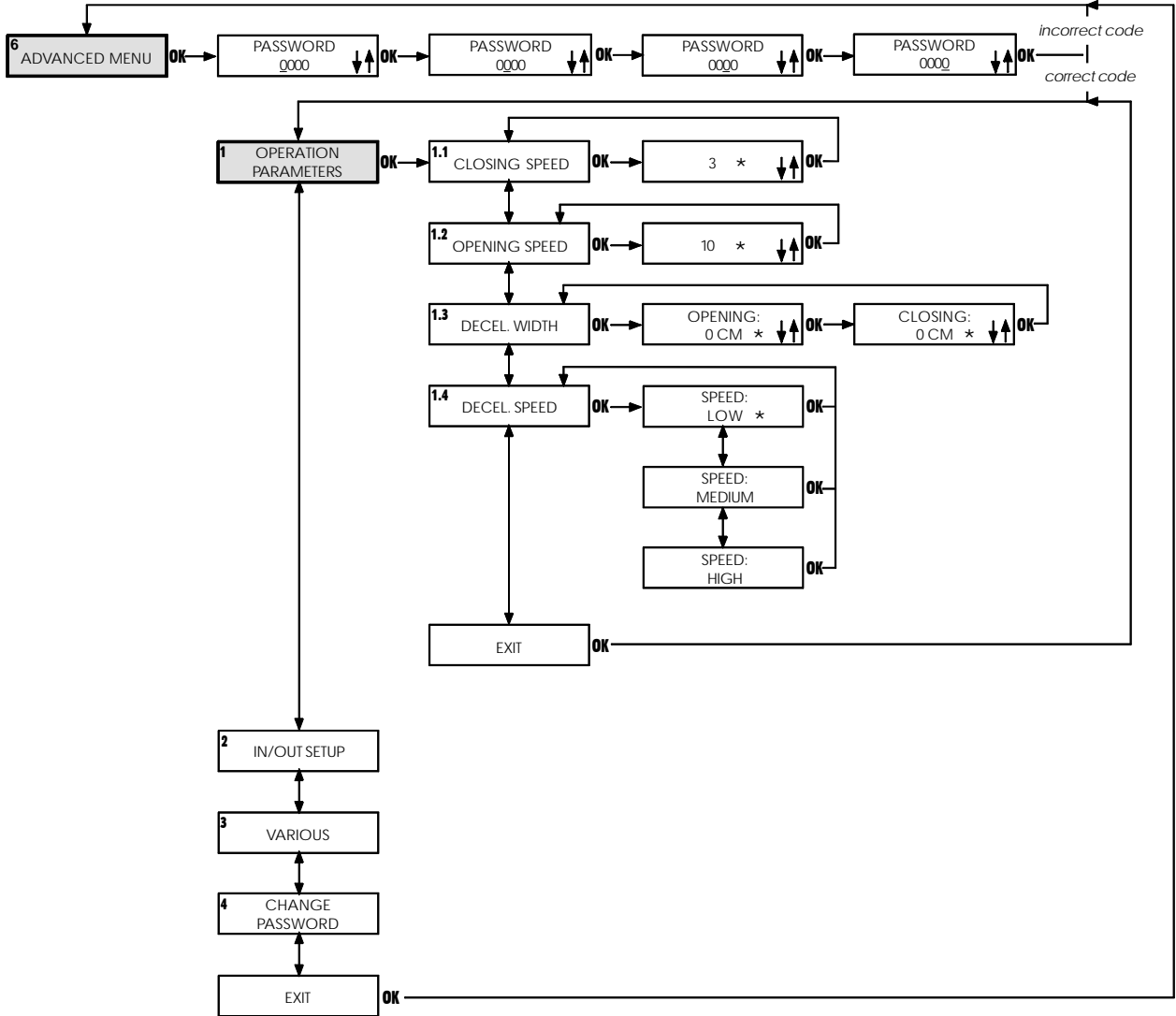

FLOW-CHART SD-KEEPER

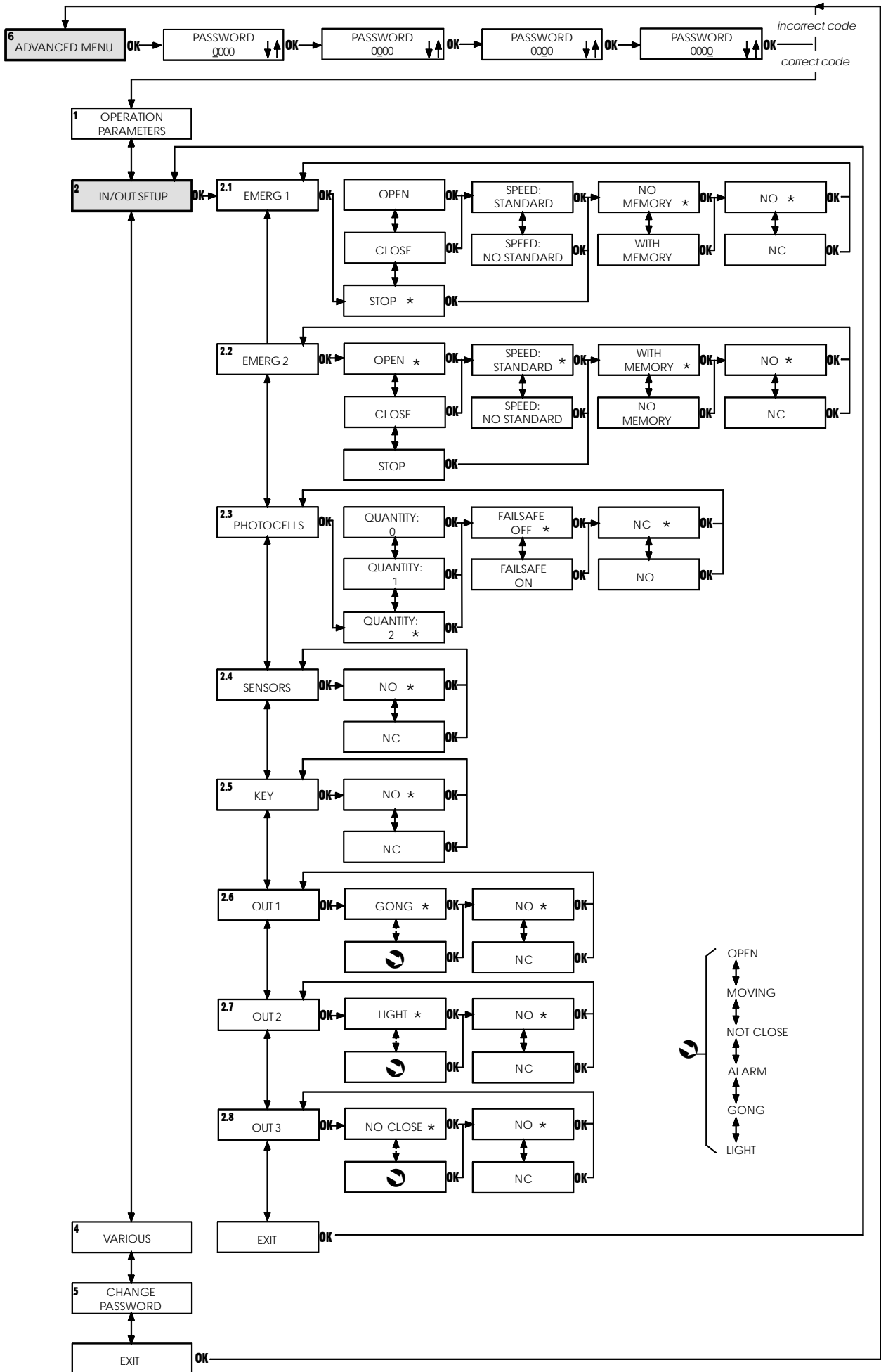

FLOW-CHART SD-KEEPER

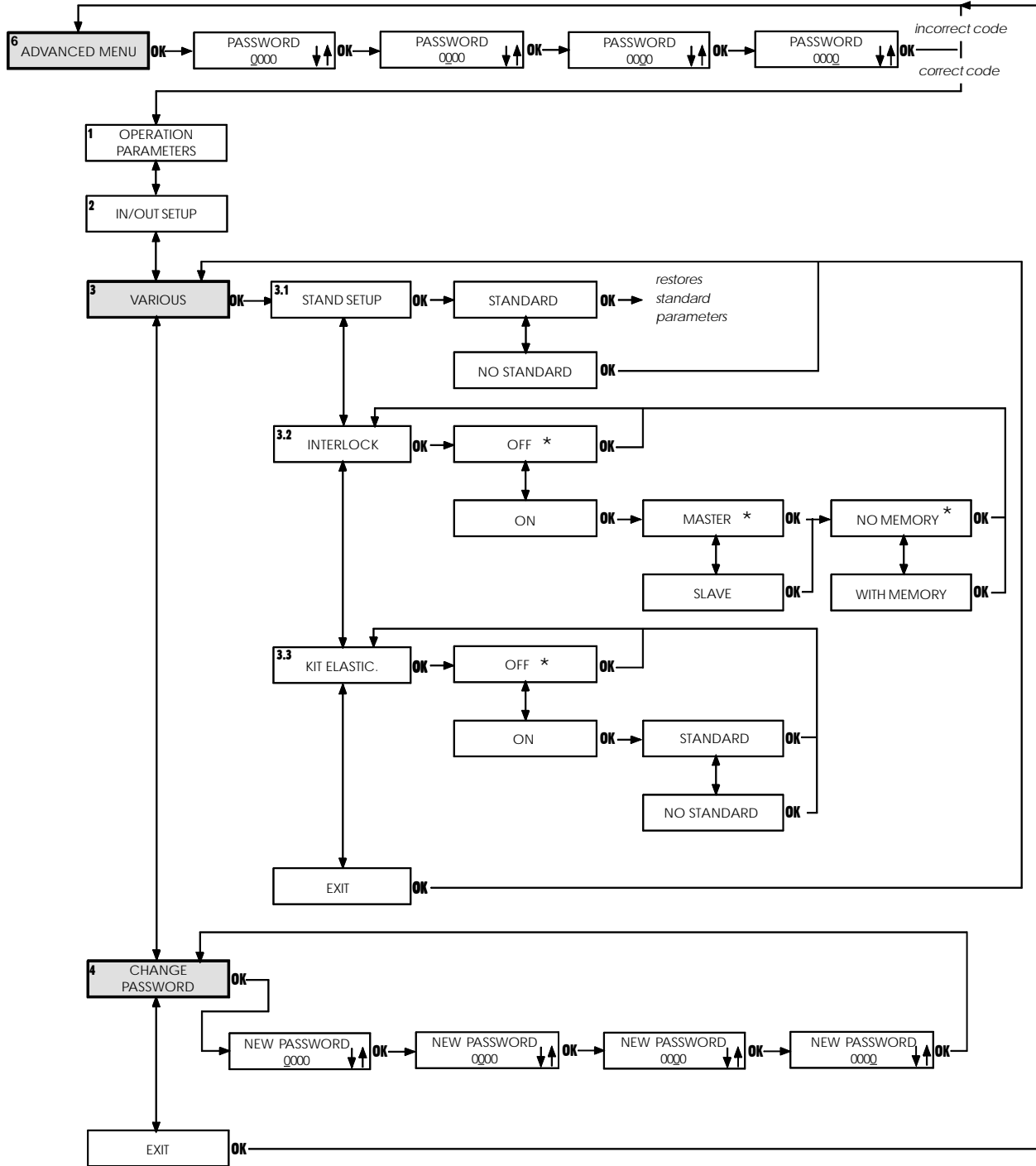

FLOW-CHART SD-KEEPER

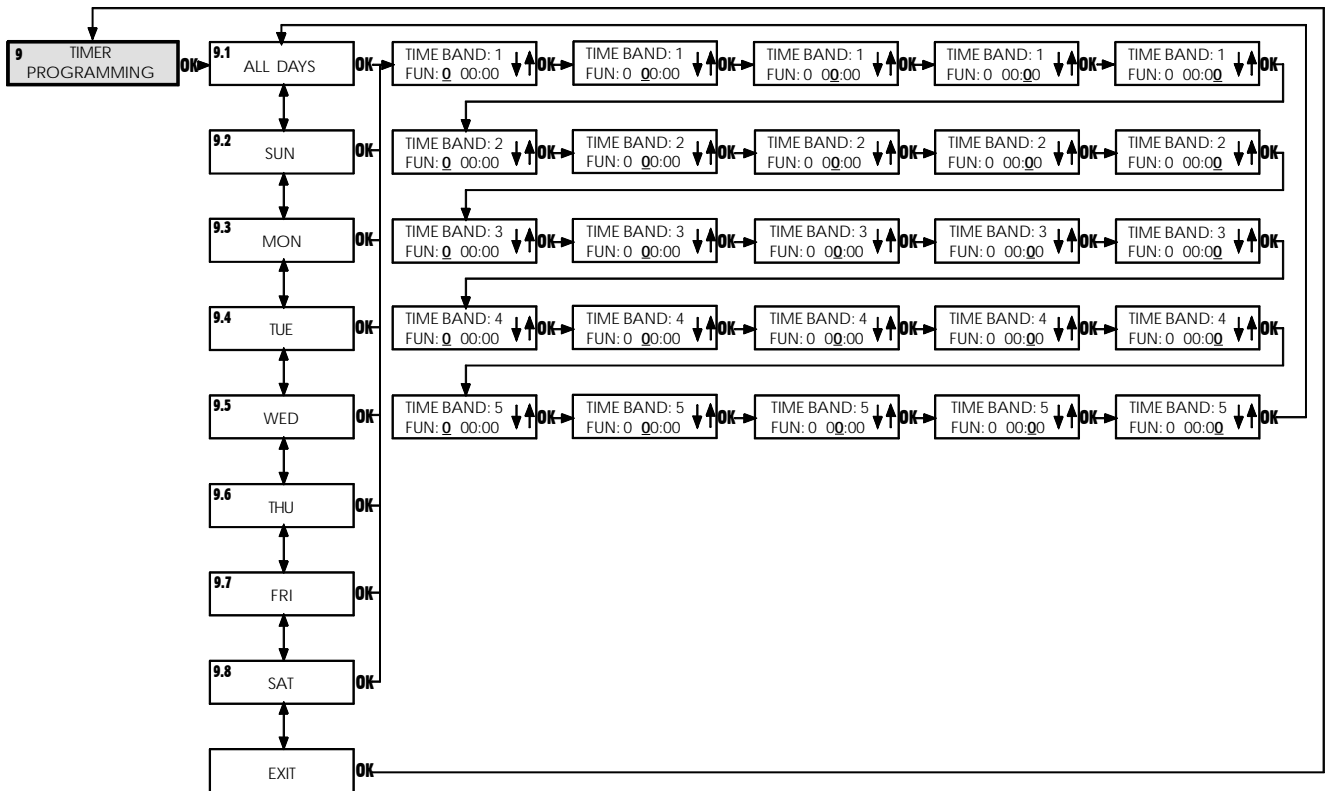
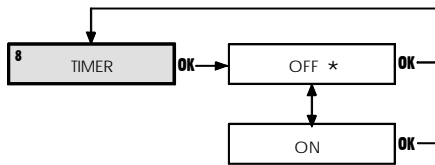
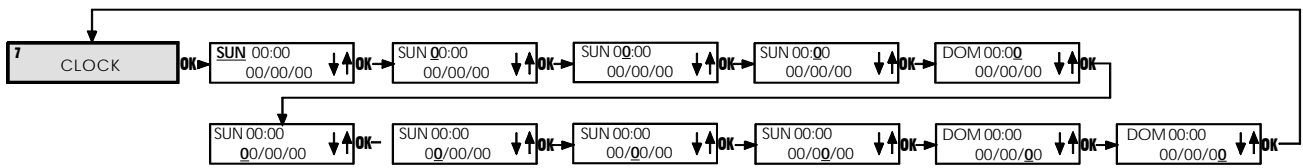

1 LANGUAGE

Selects the language for showing the messages on the display.

2 SETUP

2.1 PARTIAL OPENING

Partial opening percentage

Selects the opening percentage (referred to total opening) performed in the "partial opening" operational function.

Standard value: 50%

Adjusting range: from 10% to 90%

Standard

When the "partial opening" operational function is selected, sensor activation always causes a partial opening command.

No Standard

When the "partial opening" operational function is selected, simultaneous activation of the internal and external sensors commands total opening.

2.2 PAUSE TIME

On

Pause time enabled in the "automatic" operational function.

Pause time value

If pause time is enabled, it can be set.

Standard value: 2 sec.

Adjusting range: from 0 to 90 sec.

Off

The leaves begin the closing stage as soon as the command elements (e.g. sensors) are inactive.

2.3 NIGHT PAUSE TIME

Night pause time value

Sets pause time in the "night" operational function.

Standard value: 3 sec.

Adjusting range: from 2 to 240 sec in steps of 2.

2.4 ANTI-INTRUDER

On

In "Automatic" operating mode, the door opposes manual opening attempts by means of contrary force.

During the attempt to open, an alarm is signalled on the control board ("Error" LED flashing slowly) and on the SD-Keeper (alarm #3 - forced door).

Off

In "automatic" operating mode, when manual opening is attempted, the door opens automatically and re-closes after any pause time.

Note: In the "night" operational function, the anti-intruder is always active.

2.5 OBSTACLE DETECTION

Closing: Standard

If an obstacle is detected during closing, the door re-opens. During the next closing operation, closing is decelerated at the point where the obstacle had been detected, and continues at the slower speed until completed.

Closing: No Standard

If an obstacle is detected for 3 consecutive times at closing, the door stops in open position, and causes an alarm signal on the control board ("error" LED) and on SD-Keeper (alarm No.9 - obstacle during closing).

To restore operation, resetting is necessary either from the control board or from SD-Keeper.

Opening: Standard

If an obstacle is detected during opening, the door stops for one second and then re-closes.

During the next opening operation, opening is decelerated at the point where the obstacle had been detected, and continues at the slower speed until completed.

Opening: No Standard

If an obstacle is detected for 3 consecutive times at opening, the door stops in closed position, and causes an alarm signal on the control board ("error" LED) and on SD-Keeper (alarm No.8 - obstacle during opening).

To restore operation, resetting is necessary either from the control board or from SD-Keeper.

3 BATTERY

3.1 BATTERY KIT

Off

Battery kit not installed.

On

Battery kit installed.

3.2 BAT. OPERATION

Standard

If there is a power cut and the operating function is other than "Night", the door continues operating normally until the battery has sufficient charge reserve to perform at least one emergency movement.

The last movement operation to be executed is the one selected with function 3.3.

No Standard

In the event of a power cut, the door executes only the moving operation selected with function 3.3.

3.3 LAST OPERAT.

Opening

During battery operated functioning, the last moving operation is opening (see also function 3.2).

Closing

During battery operated functioning, the last moving operation is closing (see also function 3.2).

3.4 NIGHT BATT.

Standard

In the event of a power cut, and with the "Night" operating function selected, the control board operates immediately in low consumption mode; opening is possible only by activating emergency opening, or the key command for 3 seconds (Key input).

No Standard

In the event of a power cut and with the "Night" operating function selected, the door operates normally until the battery has sufficient charge reserve to perform at least one emergency movement.

4 LOCK

4.1 KIT LOCK

On

Lock installed.

Night

The lock locks the leaves only in the "night" operational function.

One way + night

The lock locks the leaves in the "night" and "one way" operational functions.

Always

The lock locks the leaves whenever they close, irrespective of the set operational function.

Note: During battery operated functioning, the lock locks the leaves only in "night" operational function, irrespective of the set selection.

Off

Lock not installed.

4.2 NIGHT LOCK

Standard

In the "night" operational function, with discharged batteries, the lock keeps the leaves locked.

No Standard

In the "night" operational function, the lock is released before the batteries are fully discharged.

4.3 SURVEILLANCE

Off

Surveillance device on lock not installed.

On

Surveillance device on lock installed.

5 DIAGNOSTICS

5.1 940SDM

The door's hardware model and the software of the 940SDM control board to which SD-Keeper is connected are shown.

5.2 NR. CYCLE

The count (non resettable)of the cycles effected by the door is shown.

5.3 ALARM N.

The number and description of the current alarm are shown.

No.	DESCRIPTION	MEANING
	ENERGY SAV.	Operating on low battery consumption
1	SPEED CHANGES	Speed changed, new setup required
2	BAT.OPERATION.	Door operating on battery
3	FORCED OPEN	Door forced opening in progress
4	FLAT BATTERY	Battery discharged: emergency movement not guaranteed
6	EMERG 2 ON	Emergency 2 input active
7	EMERG 1 ON	Emergency 1 input active
8	OBST.IN OPEN.	Opening obstacle detected 3 successive times; Reset necessary to restore operation
9	OBST.IN CLOS.	Closing obstacle detected 3 consecutive times; Reset necessary to restore operation
10	🔒	Lock locked in closed position
11	🔒	Lock locked in open position (with surveillance kit only)
12	🔒	Incorrect power supply to motor (VMOT absent)
13	🔒	Photocell 2 faulty (PSW2 input)
14	🔒	Photocell 1 faulty (PSW1 input)
15	🔒	Setup not possible
18	🔒	Initialisation process not possible on motor : leaf stroke too long
20	🔒	Initialisation process not possible on motor: insufficient leaf stroke
22	🔒	Initialisation process not possible on motor: too much friction
24	🔒	Motor malfunctions
25	🔒	940SDM control board faulty

RESET

Executes reset procedure.

6 ADVANCED MENU

PASSWORD

To access the advanced menu, insert the 4-digit password (default 0000).

1 OPERATION PARAMETERS

1.1 CLOSING SPEED

Sets door speed for closing.

When speed is changed with respect to the set value, an alarm is signalled on the control board ("Error" LED flashing slowly) and on the SD-Keeper (ALARM 1: speed change) - a new Setup is recommended.

Standard value: level 3.

Adjusting range: from 0 to 10

1.2 OPENING SPEED

Sets door speed for opening.

Standard value: level 10 (maximum speed)

Adjusting range: from 0 to 10

1.3 DECEL. WIDTH

Opening

Sets anticipated time value on the standard deceleration point at the opening stop position.

Standard value: 0 cm

Adjusting range: from 0 to 120 cm

Closing

Sets anticipated time value on the standard deceleration point at the closing stop position.

Standard value: 0 cm

Adjusting range: from 0 to 120 cm

1.4 DECEL. SPEED.

Speed:

Sets speed level during deceleration.

Standard value: low

Adjusting range: high/medium/low

2 IN/OUT SETUP

2.1 Emerg 1

2.2 Emerg 2

Sets the effect of the emergency commands (Emerg1 and Emerg2 inputs on 940SDM control board).

Standard setting EMERG 1:

Stop/No memory/NO

Standard setting EMERG 2:

Open/Speed: Standard/No memory/ NO

Open

Activating this command opens the door.

Close

Activating this command closes the door.

Stop

Activating this command stops the door.

Speed: Standard

The door opens or closes (according to setting) at normal speed.

Speed: No Standard

The door opens or closes (according to setting) at slow speed.

No memory

In order to keep the emergency active, the command must be maintained active (on release, the door returns to normal operation).

With memory

A pulse keeps the emergency operational;

To restore operation, resetting is necessary either from the control board or from SD-Keeper.

No

Normally open input.

Nc

Normally closed input.

2.3 Photocells

Quantity

Number of connected photocells.

Standard no.: 2

Settable no.: 0, 1, 2

When no photocells are configured and the selected status is NC (see below), there is no need to jumper connect unused inputs.

When configuring 1 photocell, you can connect to the PSW1 input of the 940SDM control board.

Failsafe Off

Failsafe test on photocells not executed.

Failsafe On

Failsafe test on photocells executed before each movement.

Nc

Normally closed input.

No

Normally open input.

2.4 SENSORS

Sets the status of "external radar" and "internal radar" commands (E-Det and I-Det inputs on 940SDM control board).

No

Normally open input.

Nc

Normally closed input.

2.5 KEY

Sets the status of the "key" command (Key input on the 940SDM control board).

No

Normally open input.

Nc

Normally closed input.

2.6 OUT 1**2.7 OUT 2****2.8 OUT 3**

Sets function or status associated with individual outputs on the 940SDM control board.

Standard setting OUT 1:

Gong/NO

Standard setting OUT 2:

Light/NO

Standard setting OUT 3:

No close/NO

Function/Status

The output is activated according to selection:

SELECTION	OUTPUT ACTIVATION
OPEN	Until the door is open
MOVING	Until door is moving
NOT_CLOSE	Until door is not closed
ALARM	Until the door is in alarm status
GONG	Intervention of photocells activates the output for 1 sec. at 0.5 sec. intervals until release.
LIGHT	In "night" operational function, when the door is commanded to open, the output is activated for 60 sec.
INTERLOCK (*)	The output is activated to create an interlock between the doors

(*) The "interlock" function cannot be selected but is automatically set on the OUT1 output when the interlock is activated (see Various/Interlock).

No

Normally open output.

Nc

Normally closed output.

3 VARIOUS**3.1 Stand Setup**

Used for checking if any non-standard programming operation was effected.

Standard

If no function was modified with respect to the standard programming, an asterisk is shown.

If the asterisk is not present, press the "OK" key and all standard programming functions are reset.

No Standard

If at least one function was modified with respect to the standard programming, an asterisk is shown.

3.2 Interlock

The interlock function makes it possible to control two sliding doors (master and slave) so that opening of one depends on closing of the other and vice versa.

Off

Interlock function not active.

On

Activates the interlock function.

Master

The master door (usually the internal one).

Slave

The slave door.

No Memory

With interlock operation, you must wait for one door to re-close before commanding the other to open: any opening pulses sent during the operating cycle of the first door, have no effect.

With Memory

With interlock operation, there is no need to wait for one door to re-close before commanding the other to open: any opening pulses sent during the operating cycle of the first door are memorised, and the second door opens automatically as soon as the first door closes.

3.2 Kit elastic.

The elastic kit is a mechanical accessory which, when installed, enables anti-panic opening of the leaves in case of a blackout.

Off

Elastic kit not installed.

On

Elastic kit installed.

Standard

When power is restored after a blackout, the door remains set in its "manual" operating function (which cannot be changed) until the device is reset by manually closing the leaf.

➔ For correct operation, the SD-Keeper must be permanently installed.

No standard

When power is restored after a blackout, the door automatically executes the movement required to reset the device.

Important!: when the system is being automatically reset, the anti-crushing device is disabled.

4 CHANGE PASSWORD

Sets the new password for accessing the advanced menu (4 digits).

7 CLOCK

Sets the current day, time and date.

8 TIMER**Off**

Timer not activated.

On

Timer activated: the operating time bands set in "9 Timer Programming" are enabled.

When the timer is activated, a "T" appears at the side of the time shown on the display and the SD-Keeper will not allow any operational selection.

The battery inside the SD-Keeper maintains the clock in operation even if power is not supplied; if correct time is lost (e.g. black-out and discharged battery), a flashing asterisk appears in place of the "T" and the timer is disabled.

9 TIMER PROGRAMMING

With the timer, you can create up to 5 different time bands for each day of the week (by setting the band starting time) and assign an operational function to each time band.

When the SD-Keeper's internal clock reaches the starting time of a band, the associated operating function is automatically set, and the door remains in this condition until the subsequent band intervenes.

Permanent connection of the SD-Keeper+Display is necessary for correct management of time bands.

Selecting the day

Selects the day of the week to create time bands.

If you select "All days", any time bands defined subsequently are included in all days of the week.

Function

Sets the operating function to be associated with the time band by referring to the following table:

FUN	MEANING
0	NOFUNCTION
1	AUTOMATIC TWO-WAY TOTAL
2	AUTOMATIC ONE-WAY TOTAL
3	AUTOMATIC TWO-WAY PARTIAL
4	AUTOMATIC ONE-WAY PARTIAL
5	DOOR TOTALLY OPEN
6	DOOR PARTIALLY OPEN
7	MANUAL
8	NIGHT

Time band starting time

Sets the activation time for the time band.

There is no need for the time bands to be in chronological order.

-TIMER PROGRAMMING EXAMPLE-

We wish to program a door operating at the following times:

- from MONDAY to FRIDAY:
 - from 8 a.m. in AUTOMATIC TWO-WAY TOTAL
 - from 6 p.m. in AUTOMATIC ONE WAY TOTAL
 - from 7 p.m. in NIGHT
- SATURDAY and SUNDAY: NIGHT for the whole day

Proceed as follows:

select ALL DAYS and set the following:

TIME BAND 1: FUN 1 8 a.m.

TIME BAND 2: FUN 2 6 p.m.

TIME BAND 3: FUN 8 7 p.m.
 TIME BAND 4: FUN 0
 TIME BAND 5: FUN 0

Select SAT and set the following:

TIME BAND 1: FUN 0
 TIME BAND 2: FUN 0
 TIME BAND 3: FUN 0
 TIME BAND 4: FUN 0
 TIME BAND 5: FUN 0

Select SUN and set the following:

TIME BAND 1: FUN 0
 TIME BAND 2: FUN 0
 TIME BAND 3: FUN 0
 TIME BAND 4: FUN 0
 TIME BAND 5: FUN 0

ACCESSORIES

LOCK

Lock card installation procedure:

- cut mains power;
- insert the lock card in any of connectors J11, J12, J13 of the 940SDM control board;
- make the electric connections;
- restore power.

Note: to avoid damaging the lock card, always insert it when power is OFF.

In the standard configuration:

- the lock locks the leaves only in the Night operating function.
- if operating on batteries in the Night mode, if the batteries become discharged, the lock continues locking the leaves.

By using SD-Keeper+Display, you can change lock operation.

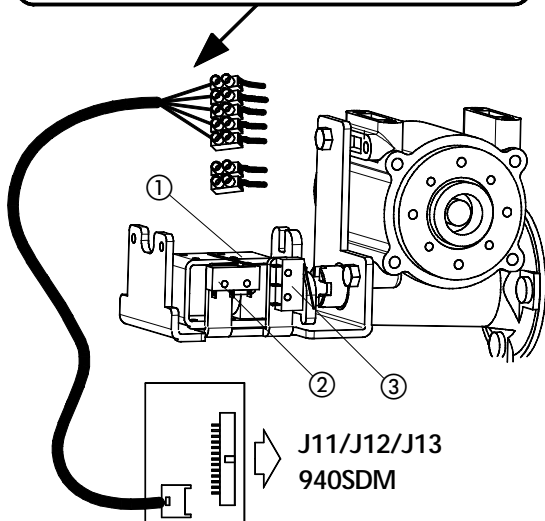
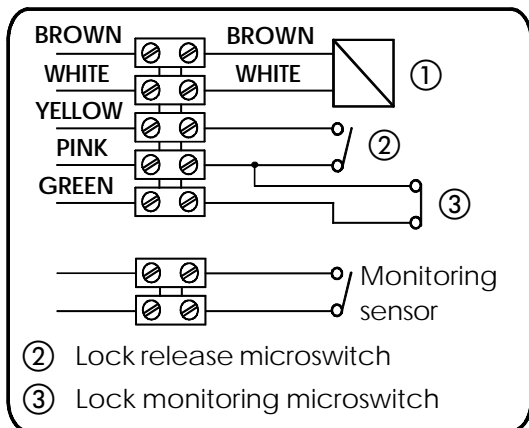

LOCK SURVEILLANCE

This accessory enables a check of lock efficiency and, in the event of an error, this is signalled by the SD-Keeper. To activate lock surveillance, the function must be set with SD-Keeper+Display.

ANTI-PANIC WITH ELASTIC

The "Kit elastic" is a mechanical accessory enabling opening of the leaves in case of a black-out.

To ensure the system operates correctly, the SD-Keeper must be permanently installed.

Elastic kit installation procedure:

- supply mains power to the door;
- execute the Setup;
- activate the elastic kit with SD-Keeper+Display;
- install the accessory mechanically.

After installation, the leaves will open when mains power fails; when mains power is restored, the elastic must be "reset".

Resetting can be done in two different ways (selected with SD-Keeper+Display):

- manually (STANDARD),
- automatically (NO STANDARD).

Resetting entails re-closing the leaves in order to apply tension to the elastic and re-connect it to the electric magnet (re-connection occurs with the leaves totally closed and the 940SDM control board powered).

If manual resetting is selected, when mains power is restored, the door is in manual mode, and this mode cannot be exited until the leaves are totally re-closed manually.

If automatic resetting is selected, when mains power is restored, the control board activates a leaf closing procedure, using much greater power than is usually required for movement; furthermore, the ANTI-CRUSHING DEVICE IS NOT ACTIVE during this procedure.

During the automatic procedure for resetting the elastic:

- if the photocells intervene, the door reopens and the disengagement procedure begins;
- the sensors are disabled;
- any Setup requests are ignored.

IMPORTANT:

- NEVER carry out a Setup procedure if the elastic has not been reset,
- do not install the batteries with this accessory.

ANTI-PANIC BY BREAK-OUT

This accessory enables the leaves to be opened by pressure; to install it, refer to the specific instructions.

If installing the anti-panic by break-out facility, a sensor (according to Standards prEN12650-1 and prEN12650-2) must be installed. It must be connected to the EMERG1 input (via SD-Keeper+Display) configured for commanding immediate stop of the movement.

BATTERY KIT

Battery card installation procedure:

- cut mains power;
 - insert the battery card in connector J11, J12 or J13 of the 940SDM control board;
 - restore mains power;
 - using the SD-Keeper+Display, activate the "Battery Kit" and set the required operating parameters (the standard configuration is described further below);
 - connect the batteries to the battery card on connector J2.
- IMPORTANT: TO AVOID DAMAGING THE BATTERY CARD:**
- ALWAYS** insert and remove the battery card while mains power is OFF.
 - connect the batteries (connector J2) only when the battery card has already been inserted.

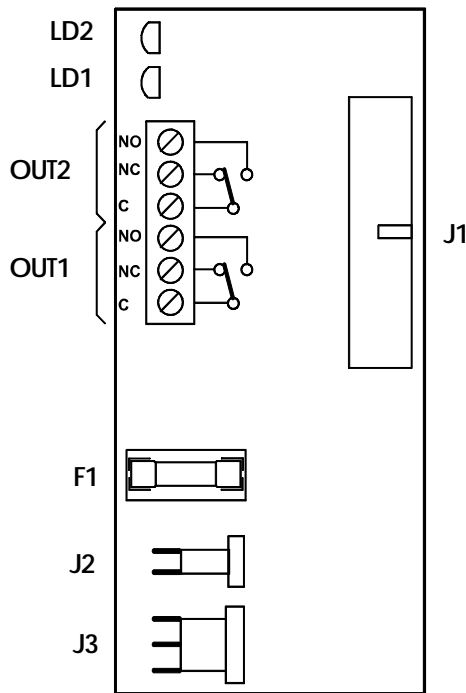

F1	Fuse 20 T5A/250V (battery protection)
J1	Connection to 940SDM control board
J2	Battery connection
J3	Connection to J10 of 940SDM board
OUT 1	Relay output (Com/NC/NO)
OUT 2	Relay output (Com/NC/NO)
LD1 (green)	Door power supply mode
LD2 (red)	Battery charge status

By using the SD-Keeper+Display, you can select door behaviour in battery operation mode, so that, if mains power fails:

OPERATING FUNCT. other than NIGHT and STANDARD BAT. OPERATION programming:

- the control board continues to operate normally until the battery has only sufficient reserve charge to perform at least one emergency movement, after which
- the last programmed movement is performed (opening or closing), and finally
- the 940SDM control board goes into ENERGY SAVING status.

OPERATING FUNCT. other than NIGHT and NO STANDARD BAT. OPERATION programming:

- the last programmed movement is immediately performed (opening or closing), after which
- the 940SDM control board goes into ENERGY SAVING status.

NIGHT OPERATING FUNCT. and NIGHT STANDARD BAT. OPERATION programming:

- the 940SDM control board goes into NIGHT ENERGY SAVING status.

NIGHT OPERATING FUNCT. and NIGHT NO STANDARD BAT. OPERATION programming:

- the control board continues to operate normally until the battery has only sufficient reserve charge to perform at least one emergency movement, after which
- the 940SDM control board goes into NIGHT ENERGY SAVING status.

ENERGY SAVING (other than Night operating function)

- +VAC is switched OFF;
- SD-Keeper shows ENERGY SAV. on the Display, the alarm is signalled, back lighting goes OFF, menus cannot be scrolled, and only the keys for changing the operating function remain active.

NIGHT ENERGY SAVING (Night operating function)

- +VAC is switched OFF;
- SD-Keeper completely OFF.

These statuses can be exited in the following ways:

WAKE-UP PROCEDURE (KEY INPUT FOR 3 SEC)

If the last selected movement was opening, the SD-Keeper re-activates itself for night pause time and then returns to ENERGY SAVING status.

If the last selected movement was closing, opening is executed. When the door is open, the SD-Keeper re-activates itself for night pause time, after which the +Vacc is re-activated too (to allow the photocells to operate) and the door re-closes (SD-Keeper resumes its ENERGY SAVING status).

BY ACTIVATING AN EMERGENCY INPUT (EMERG1 or EMERG2)

Providing it was set, the emergency movement is executed. SD-Keeper stays ON during the period when the emergency status remains active. Vacc is re-activated if a closing movement is requested.

BY USING THE LOCK KNOB

See the WAKE-UP function.

NOTE: by using SD-Keeper+Display, you can configure lock operation in battery-powered Night mode.

	GREEN LED ON	RED LED OFF
LED RED ON	- the door is mains powered - battery at very low charge level (1) - OUT1 not active - OUT2 active	- the door is battery-powered - battery fully discharged (3) - OUT1 not active - OUT2 not active
LED RED FLASHING	- the door is mains powered - battery now recharging; if mains power fails, no emergency movement is guaranteed (2) - OUT1 not active - OUT2 active	- the door is battery-powered - battery now discharging; at least one emergency movement is guaranteed (2) - OUT1 not active - OUT2 not active
LED RED OFF	- the door is mains powered - the battery is charged; if mains power fails, door movement is guaranteed - OUT1 active - OUT2 active	- the door is battery-powered - the battery is charged and can move the door - OUT1 active - OUT2 not active

(1) If the red LED does not start to flash within about 30 mins, the causes may be as follows:

- incorrect battery connection or no battery connection;
- fuse F1 interrupted;
- batteries or battery card damaged.

(2) recharging time for fully discharged batteries: about 14 hours.

(3) No emergency movement is possible: the accessories connected to +Vacc and SD-Keeper are turned OFF and the Manual operating mode is set.

INTERLOCK

INTERLOCK WITH INTERNAL SENSORS

This application is recommended when the distance between the two doors is sufficient to avoid interference in the detection ranges of the two internal sensors.

- Make the connections between the J6 terminal boards of the two 940SDM control boards and the sensors as shown in figure 8.
- Program the following functions:
 - "interlock" active on both doors,
 - select the "master" option for the internal door, and the "slave" option for the external one,
 - select, for both doors, option "interlock with no memory" or "interlock with memory" (refer to explanations in the programming flow-charts).

Important:

- The sensors must be connected ONLY to the KEY input of the equipment;
- The interlock will operate only if both doors are set to the NIGHT or ONE WAY operating function.

Operation

These are the interlock operational stages:

- 1) The person on the outside activates sensor S1 of door A;
- 2) Door A opens;
- 3) The person enters the internal space between the two doors;
- 4) Door A closes after the night pause time elapses;
- 5) The person activates sensor S3 of door B (If the "Interlock with memory" option was selected, there is no need to wait for the first door to close totally in order to activate the sensor of the second door);
- 6) Door B opens;
- 7) The person exits;
- 8) Door B closes after the night pause time elapses.

The operation is identical if the person comes from the opposite direction.

INTERLOCK WITHOUT INTERNAL SENSORS

This application is recommended if the doors are so near to one another that the two internal sensors cannot be used; two push-buttons are provided for activating the doors from the outside.

- Make the connections between the J6 terminal boards of the two 940SDM control boards, of the push-buttons and additional electronic components as shown in figure 9.
- Program the following functions:
 - "interlock" active on both doors,
 - select the "master" option for the internal door, and the "slave" option for the external one,
 - select the "interlock with memory" option for both doors (refer to explanations in the programming flow-charts).

Important:

- The push-buttons must be connected ONLY to the KEY input of the equipment;
- The interlock will operate only if both doors are set to the NIGHT or ONE WAY operating function.

Operation

These are the interlock operational stages:

- 1) The person on the outside activates push-button P1 of door A;
 - 2) Door A opens;
 - 3) The person enters the internal space between the two doors;
 - 4) Door A closes after the night pause time elapses;
 - 5) Door B opens automatically;
 - 7) The person exits;
 - 8) Door B closes after the night pause time elapses.
- The operation is identical if the person comes from the opposite direction.

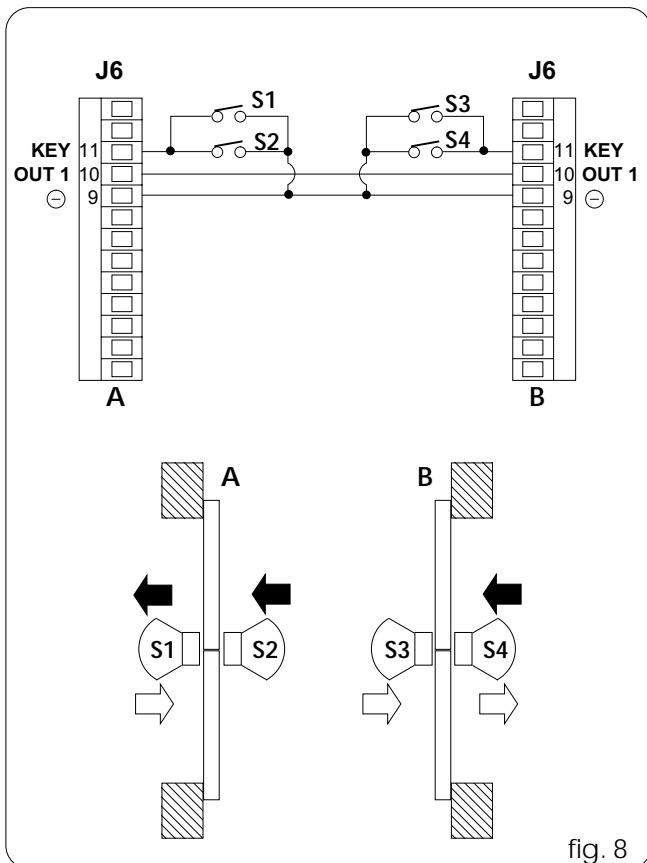

fig. 8

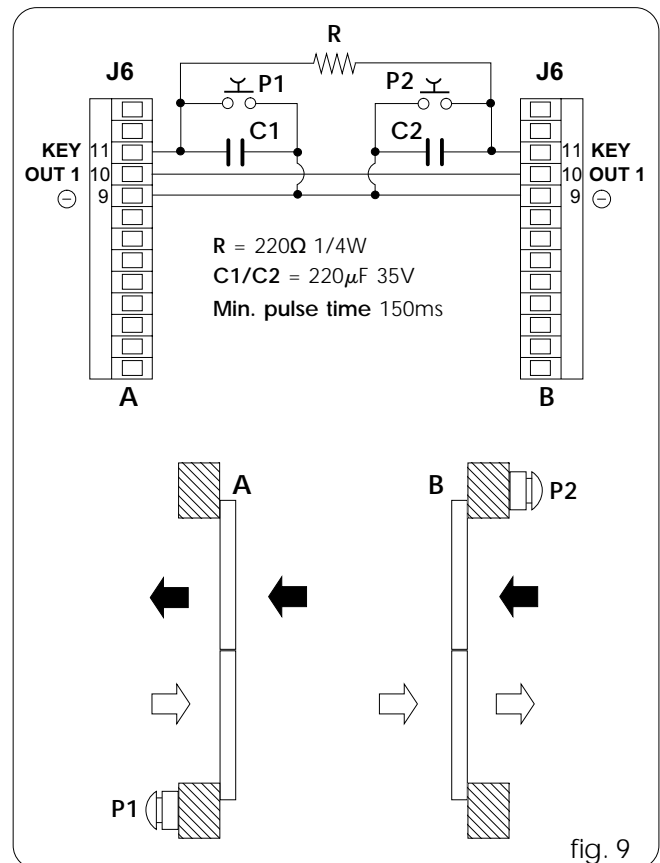

fig. 9

DIAGNOSTICS GUIDE

The following is a list of the specified alarms plus the relevant explanation/solution.

SD-Keeper+Display shows the alarm number and description on the Diagnostics menu.

Only the SD-Keeper shows the type of alarm by a combination of flashing LEDs (referring to the figure on the side).

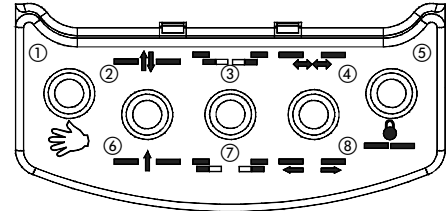

DESCRIPTION	CAUSE	NOTES	ACTIONS	LED
ENERGY SAV.	The 940SDM control board is operating in battery powered/low consumption mode	In this mode, SD-Keeper's back-lighting is OFF and menus cannot be scrolled on the display.	(see battery kit instructions) However, the push-buttons for changing the operating functions are active.	2
1 SPEED CHANGES	Closing speed was changed.		Execute a new SETUP	7
2 BAT. OPERATION	940SDM control board operating on battery	GREEN LED on battery card is OFF	In the event of a power cut, this is the normal battery-powered operation signal However, if mains power is available, check: • is the 5x20 T1A fuse of the transformer in the power supply unit interrupted? • is the F2 5x20 T1A fuse on the 940SDM control board interrupted? • Is the 220V~ mains power supply correctly connected? • Is connector J1 fitted correctly on the 940SDM control board? If the alarm persists, replace the 940SDM control board. If the alarm persists, replace the transformer.	3
3 FORCED OPEN	Someone is now trying to force the door.	This signal is generated only if STANDARD ANTI-INTRUDER is set.		3 7
4 FLAT-BATTERY	The battery is discharged: emergency movement is not guaranteed at changeover from mains-powered to battery-powered mode.	RED LED on battery card is ON steady.	If the alarm goes on for more than one hour, check the following: • connections to battery • is the battery card inserted correctly? • is the 5x20 T5A fuse on the battery card interrupted? • are the batteries efficient? If the alarm persists, replace the battery card. If the alarm persists, replace the batteries.	4
6 EMERG 2 ON	Emergency input 2 active.	This signal is shown whenever the EMERG2 emergency contact is active. If the WITH MEMORY function was selected for this input, the signal continues even when the contact is no longer active.	If the WITH MEMORY function was selected for the EMERG2 input, when the contact is restored, RESET is necessary to cancel the signal.	3 4
7 EMERG 1 ON	Emergency input 1 active.	This signal is shown whenever the EMERG1 emergency contact is active. If the WITH MEMORY function was selected for this input, the signal continues even when the contact is no longer active.	If the WITH MEMORY function was selected for the EMERG1 input, when the contact is restored, RESET is necessary to cancel the signal.	3 4 7
8 OBST. IN OPEN.	An obstacle was detected 3 consecutive times during the opening movement.	This signal is shown only if the following function was selected: OBSTACLE DETECTION - -> OPENING: NO STANDARD	Remove the obstacle and execute RESET to restore operation.	8
9 OBST. IN CLOS.	An obstacle was detected 3 consecutive times during the closing movement.	This signal is shown only if the following function was selected: OBSTACLE DETECTION - -> CLOSING: NO STANDARD	Remove the obstacle and execute RESET to restore operation.	7 8
10	The lock is locked in closed position.	This signal is shown only if the lock was installed: • without surveillance: the door attempts to release the lock 3 times and then stops in a state from which it can exit only by a RESET or by turning the emergency release knob. • with surveillance: the door stops immediately in a state from which it can exit only by a RESET or by turning the emergency release knob	Check the following: • is the lock card inserted correctly? • are the lock connections good? • is the lock operating correctly? • is the lock surveillance kit (if any) correctly fitted and connected? If the alarm continues even after RESET, replace the lock card and/or the lock.	3 8
11	Lock not closing	This signal is shown only if a SURVEILLANCE KIT was installed ON THE LOCK, and was programmed.	Check the following: • is the lock card inserted correctly? • are the lock connections good? • is the lock operating correctly? • is the lock surveillance kit correctly fitted and connected?	3 7 8
12	Incorrect power supplied to motor.	The +VMOT green LED is OFF.	Check the following: • is the F1 5x20 T6.3A fuse on the 940SDM control board interrupted? • is connector J1 correctly fitted?	4 8
13	Photocell 2 faulty.	This signal is shown only if the FAILSAFE function is active and 2 photocells were configured.	Check the following: • is photocell 2 aligned correctly? • photocell 2 connections • is photocell 2 in good condition and efficient?	4 7 8

14	Photocell 1 faulty.	This signal is shown only if the FAILSAFE function is active and at least 1 photocell was configured.	Check the following: <ul style="list-style-type: none"> • is photocell 1 aligned correctly? • photocell 1 connections • is photocell 1 in good condition and efficient? 	3 4 8
15	SETUP execution is impeded in some way.	When the trouble fault is removed, SETUP starts automatically.	Check the following: <ul style="list-style-type: none"> • the set operating function is not MANUAL, NIGHT, or DOOR OPEN. • operation is not battery-powered • photocells are not engaged • no emergency input is active • motor power supply absent (+VMOT LED OFF) 	3 4 7 8
18	SETUP procedure cannot be completed because excessively large (over 3m) transit space was detected.	When this signal is generated, the ERROR LED on the 940SDM control board is ON steady and the door is locked.	Reduce leaf travel and execute a new SETUP	2 3
20	SETUP procedure cannot be completed because insufficient (less than 70cm) transit space was detected.	When this signal is generated, the ERROR LED on the 940SDM control board is ON steady and the door is locked.	Increase leaf travel and execute a new SETUP	2 4
22	The SETUP procedure cannot be completed because excessive friction or excessive leaf weight was detected.	When this signal is generated, the ERROR LED on the 940SDM control board is ON steady and the door is locked.	<ul style="list-style-type: none"> • cut power or set the MANUAL operating function, and then manually check if the leaves are moving correctly. • check weight of leaves 	2 3 4
24	A motor fault was detected during operation.	When this signal is generated, the ERROR LED on the 940SDM control board is ON steady and the door is locked.	Check the following: <ul style="list-style-type: none"> • is connector J3 fitted correctly? • is the motor efficient? If the ERROR LED is flashing, when the error cause is eliminated, the door resumes operating normally; if, instead, the ERROR LED is ON steady, execute a SETUP when the cause has been removed. If the alarm persists, replace the 940SDM control board. If the alarm persists, replace the motor.	2 8
25	940SDM control board failure		Replace the 940SDM control board	2 7 8
All the LEDs of the operating functions are flashing.	No communication between SD-Keeper and 940SDM control board.		Check the following: <ul style="list-style-type: none"> • connection length must not exceed 50 m • each connection cable must have a minimum diameter of 0.5mm² If the alarm persists, replace the SD-Keeper. If the alarm persists, replace the 940SDM control board.	

TROUBLESHOOTING

The following will help you identify and solve some particular states.

	STATE	SUGGESTION
A	SD-KEEPER off	<ul style="list-style-type: none"> no mains power supplied and the 940SDM control board is battery-powered in NIGHT operating function, and in energy saving statuses. connection to the 940SDM control board is interrupted: check the connection cables and wiring between SD-Keeper and the 940SDM control board 940SDM control board not operating correctly; replace the 940SDM control board
B	LEDs MAIN, V _{ACC} , VMOT and +24V OFF	<ul style="list-style-type: none"> check if the F2 5x20 T1A fuse on the 940SDM control board is interrupted is the 5x20 T1A fuse inside the power supply unit interrupted? is connector J2 fitted correctly on the 940SDM control board? check connection to the power supply unit 940SDM control board not operating correctly; replace the 940SDM control board
C	MAIN LED OFF; V _{ACC} , VMOT and +24V LEDs all ON	<ul style="list-style-type: none"> mains power not supplied and the 940SDM control board is battery-powered if mains power is being supplied, see point B
D	MAIN and V _{ACC} LEDs OFF; VMOT and +24V LEDs ON	<ul style="list-style-type: none"> no mains power supplied, the 940SDM control board is battery-powered and in energy saving statuses. if mains power is being supplied, see point B
E	VMOT LED OFF; MAIN, V _{ACC} and +24V LEDs ON	<ul style="list-style-type: none"> is the F1 5x20 T6.3A fuse on the 940SDM control board interrupted? is connector J3 fitted correctly on the 940SDM control board? check if the power supply unit and the control board are efficiently connected 940SDM control board not operating correctly; replace the 940SDM control board
F	VMOT and V _{ACC} LEDs OFF; MAIN and +24V LEDs ON	<ul style="list-style-type: none"> this state occurs when the control board software is being updated there may be condensation on the board: cut power and dry the dampness. 940SDM control board not operating correctly; replace the 940SDM control board
G	ERROR LED flashing slowly	<ul style="list-style-type: none"> alarm in progress: connect the SD-Keeper to find the alarm and take the appropriate action (see the diagnostics guide)
H	door locked and ERROR LED ON	<ul style="list-style-type: none"> SETUP must be executed alarm in progress: connect the SD-Keeper to find the alarm and take the appropriate action (see the diagnostics guide) check motor connection check motor encoder connection check the condition of the encoder connection flat cable
I	door NOT executing SETUP and ERROR LED flashing slowly	<ul style="list-style-type: none"> SETUP execution impeded (see 940SDM control board instructions)
L	door NOT CLOSING and ERROR LED off	<ul style="list-style-type: none"> photocell/s engaged make sure that the selected operating function is not DOOR OPEN (if no SD-Keeper is installed, make sure that input 8 of the J6 terminal board is not jumper connected to the negative) make sure that the selected operating function is not MANUAL check motor connection check if power is being supplied to the motor (VMOT LED ON)
M	door NOT OPENING and ERROR LED off	<ul style="list-style-type: none"> make sure that the selected operating function is not MANUAL make sure that the selected operating function is not NIGHT (if no SD-Keeper is installed, make sure that input 7 of the J6 terminal board is not jumper connected to the negative) check motor connection make sure that the lock is not locked check if power is being supplied to the motor (VMOT LED ON)
N	door CLOSES instead of OPENING and vice versa	<ul style="list-style-type: none"> reverse the position of dip-switch 1 on the 940SDM control board and execute a SETUP
O	door moving for short distances only	<ul style="list-style-type: none"> check if encoder connector J4 is correctly inserted check condition of the encoder check the condition of the encoder connection flat cable
P	door movements very slow	<ul style="list-style-type: none"> using the SD-Keeper+Display, check if the selected speed levels are as required using the SD-Keeper+Display, check if the selected deceleration distances are as required
Q	ERROR LED flashing rapidly	<ul style="list-style-type: none"> door executing a SETUP; wait for the procedure to end door executing a RESET; wait for the procedure to end with the KIT ELASTIC installed, the door is resetting the elastic; wait for the procedure to end

Le descrizioni e le illustrazioni del presente manuale non sono impegnative. La FAAC si riserva il diritto, lasciando inalterate le caratteristiche essenziali dell'apparecchiatura, di apportare in qualunque momento e senza impegnarsi ad aggiornare la presente pubblicazione, le modifiche che essa ritiene convenienti per miglioramenti tecnici o per qualsiasi altra esigenza di carattere costruttivo o commerciale.

The descriptions and illustrations contained in the present manual are not binding. FAAC reserves the right, whilst leaving the main features of the equipments unaltered, to undertake any modifications it holds necessary for either technical or commercial reasons, at any time and without revising the present publication.

Les descriptions et les illustrations du présent manuel sont fournies à titre indicatif. FAAC se réserve le droit d'apporter à tout moment les modifications qu'elle jugera utiles sur ce produit tout en conservant les caractéristiques essentielles, sans devoir pour autant mettre à jour cette publication.

Die Beschreibungen und Abbildungen in vorliegendem Handbuch sind unverbindlich. FAAC behält sich das Recht vor, ohne die wesentlichen Eigenschaften dieses Gerätes zu verändern und ohne Verbindlichkeiten in Bezug auf die Neufassung der vorliegenden Anleitungen, technisch bzw. konstruktiv/kommerziell bedingte Verbesserungen vorzunehmen.

Las descripciones y las ilustraciones de este manual no comportan compromiso alguno. FAAC se reserva el derecho, dejando inmutadas las características esenciales de los aparatos, de aportar, en cualquier momento y sin comprometerse a poner al día la presente publicación, todas las modificaciones que considere oportunas para el perfeccionamiento técnico o para cualquier otro tipo de exigencia de carácter constructivo o comercial.

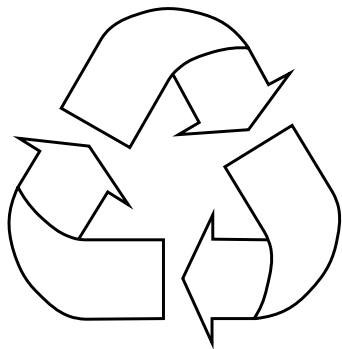

FAAC per la natura

- La presente istruzione è realizzata al 100% in carta riciclata.
- Non disperdete nell'ambiente gli imballaggi dei componenti dell'automazione bensì selezionate i vari materiali (es. cartone, polistirolo) secondo prescrizioni locali per lo smaltimento rifiuti e le norme vigenti.

FAAC for the environment

- The present manual is produced in 100% recycled paper
- Respect the environment. Dispose of each type of product packaging material (card, polystyrene) in accordance with the provisions for waste disposal as specified in the country of installation.

FAAC der Umwelt zuliebe

- Vorliegende Anleitungen sind auf 100% Altpapier gedruckt.
- Verpackungstoffe der Antriebskomponenten (z.B. Pappe, Styropor) nach den einschlägigen Normen der Abfallwirtschaft sortenrein sammeln.

FAAC écologique

- La présente notice a été réalisée 100% avec du papier recyclé.
- Ne pas jeter dans la nature les emballages des composants de l'automatisme, mais sélectionner les différents matériaux (ex.: carton, polystyrène) selon la législation locale pour l'élimination des déchets et les normes en vigueur.

FAAC por la naturaleza.

- El presente manual de instrucciones se ha realizado, al 100%, en papel reciclado.
- Los materiales utilizados para el embalaje de las distintas partes del sistema automático (cartón, poliestireno) no deben tirarse al medio ambiente, sino seleccionarse conforme a las prescripciones locales y las normas vigentes para el desecho de residuos sólidos.

FAAC

FAAC S.p.A.

Via Benini, 1

40069 Zola Predosa (BO) - ITALIA

Tel.: 051/61724 - Fax: 051/758518

www.faacgroup.com



Timbro del Rivenditore:/Distributor's Stamp:/Timbre de l'Agent:/ Fachhändlerstempel:/Sello del Revendedor:



FAAC para la naturaleza
100% papel reciclado



FAAC ist umweltfreundlich
100% Altpapier



FAAC pour la nature
papier recyclé 100%



FAAC for nature
recycled paper 100%



FAAC per la natura
carta riciclata 100%

